



100% PURE SINE WAVE HOME INVERTER

# USER'S MANUAL ENERGY STORAGE INVERTER

3KW/5.2KW

The software supports installation on Windows systems.  
Scan the QR code for download or visit the website for  
downloading: <https://sw.mustpower.com>



Appliances



PC



TV



Air-  
conditioning



Fridge



Washing  
machine

4200-100025-0000

# Contents

<b>ABOUT THE MANUAL</b> .....	1
Purpose.....	1
Scope.....	1
<b>SAFETY NOTICE</b> .....	1
<b>INTRODUCTION</b> .....	2
Features.....	2
Basic System Structure.....	2
Product Overview.....	3
<b>PART LIST</b> .....	4
<b>ELECTRICAL CONNECTION</b> .....	4
AC Input /Output Terminal Blocks.....	4
AC Input Socket.....	5
AC Output Socket.....	5
PV Connection.....	5
PV Panel Selection.....	5
PV Panel Connection.....	6
MC4 Connector.....	6
PV Terminal Block.....	6
Dry Contact Signal.....	7
Upper Computer Communication.....	7
<b>OPERATION</b> .....	8
Operation and Display Panel.....	8
LCD Display Icons.....	9
Power ON/OFF.....	10
Input and Output .....	10
Monitoring.....	10
Parameters Modification.....	11
Fault Reference Code .....	13
Warning Indicator .....	14
<b>TROUBLE SHOOTING</b> .....	15
<b>SPECIFICATIONS</b> .....	16

## ABOUT THE MANUAL

### Purpose

This manual describes the operation and troubleshooting of the equipment. Please read this manual carefully before operation.

Retain this manual for future reference.

### Scope

This manual provides safety guidelines and information on tools and wiring.

### The following situations are not covered by the warranty :

- (1) Overdue the warranty period .
- (2) The serial number has been changed or lost.
- (3) The battery capacity is the lowest or the appearance of the device is damaged.
- (4) External factors such as transportation,negligence,etc.
- (5) This equipment has been damaged by an irresistible natural disaster .
- (6) Damage caused by not following the power supply conditions or operating environment .

## SAFETY NOTICE



**WARNING:** This chapter contains important safety and operating instructions. Read and save this manual for future reference.

- 1.** Before using this unit , please read all instructions and precautions on this unit , understand all relevant chapters in this manual to Prevent explosion which may lead to personal injury and battery damage.
- 2.** Do not disassemble the unit . When service or repair is required , send it to a professional service center . Incorrect assembly may result in electric shock or fire.
- 3.** To reduce the risk of electric shock , disconnect all wiring before attempting any maintenance or cleaning . Turning off the device does not reduce this risk.
- 4.** Caution - Only professionals should install this device.
- 5.** Grounding Instructions - This equipment should be connected to a permanently grounded wiring system. Be sure to comply with local requirements and regulations to use this device.

## INTRODUCTION

This is a multi-functional photovoltaic energy storage power station, integrated with battery, MPPT solar charge controller, high frequency pure sine wave inverter and UPS function module into one , which is suitable for outdoor backup electric compartment and spontaneous self-use system .

MPPT solar charge controller adopts advanced MPPT method and intelligent battery management design, which ensures the acquisition of maximum energy. High frequency pure sine wave inverter adopts high frequency design , achievement high rate density , small size , simple operation and other advantages; The whole machine has high efficiency and the empty load loss is small ,which uses large capacity basket and high-density hammer pool to improve portability of the system.

## Features

- Pure sine Wave AC Output Inverter with 3KW/5.2KW rated power and power factor 1.
- High power density with universal wheels and high portability.
- Real time input/output power and SOC of battery on the LCD screen.
- 5V USB and 12V DC output supported.
- Input voltage and voltage range configurable on upper computer.
- Protection functions such as overload, over temperature and short circuit.

## Basic System Structure

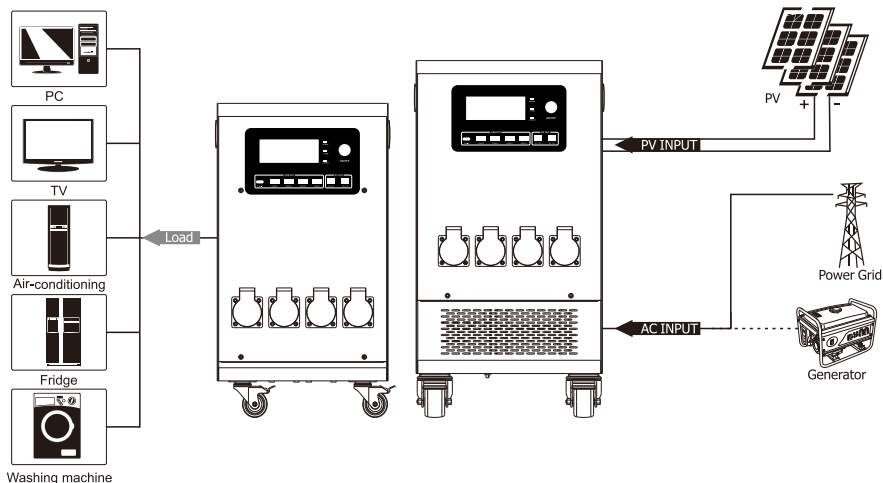



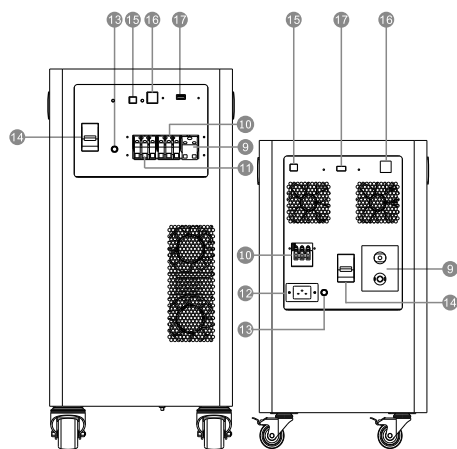
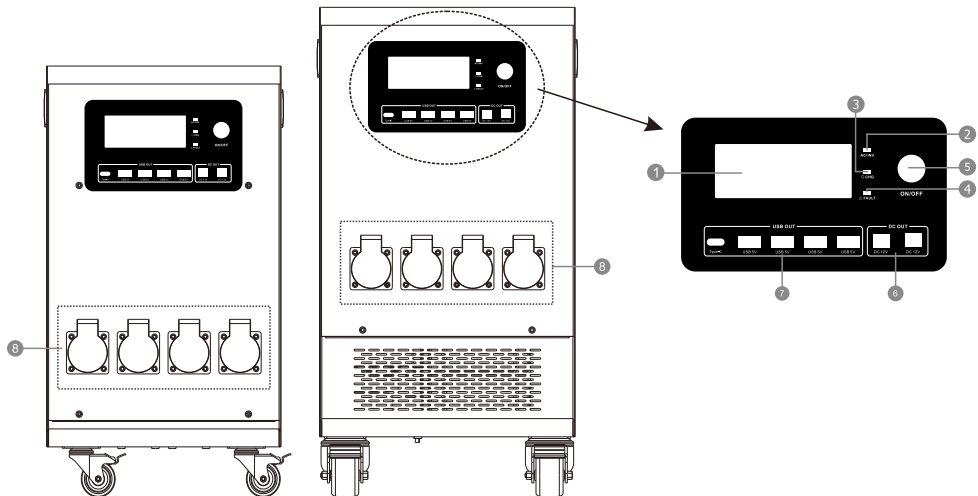

## Product Overview

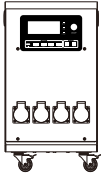

1. LCD display
2. Status Indicator
3. Charge/discharge Indicator
4. Fault Indicator
5. ON/OFF Button
6. DC 12V output
7. DC 5V USB output
8. AC output sockets
9. PV input terminal
10. AC output terminal block
11. AC input terminal block
12. AC input socket
13. AC input over-current protection
14. Battery Breaker
15. USB-A communication port
16. Dry Contact
17. USB WiFi

## PART LIST

Make sure nothing in the package is damaged. You should have received the following items inside the package.

			
Machine X 1	User manual X 1	Mains input line X 1 (Only for 3KW Model)	USB cable X 1

## ELECTRICAL CONNECTION

### AC Input /Output Terminal Blocks

**CAUTION!** There are two terminal blocks with "INPUT" and "OUTPUT" markings for 5.2KW model. Please do NOT misconnect input and output connectors. There is a output terminal block for 3KW model.

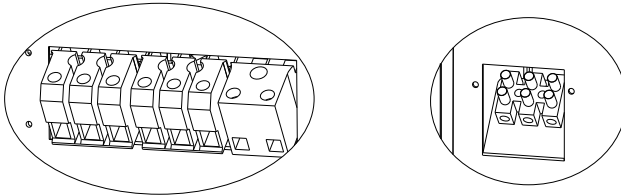

**CAUTION!** Before connecting to AC input power source, please install a separate AC breaker between inverter and AC input power source. This will ensure the inverter can be securely disconnected during maintenance and fully protected from over current of AC input. The recommended spec of AC breaker is 40A for 5.2KW model.

**WARNING!!** All wiring must be performed by a qualified person.

**WARNING!!** It's very important for system safety and efficient operation to use appropriate cable for AC input connection. To reduce risk of injury, please use proper recommended cable size as below.

Product Model	Typical Amperage	AWG No.
3KW	13A	12AWG
5.2KW	23A	10AWG

Please follow below steps to implement AC input/output connection for 5.2KW model, and to implement AC output connection for 3KW model:

1. Before making connection, be sure to open AC disconnecter first.
2. Remove insulation sleeve 10mm for six conductors. Shorten phase L and N conductor 3mm.
3. Insert AC input wires according to polarities indicated on terminal block and tighten the terminal screws. Be sure to connect PE protective conductor(⊕) first.

⊕ → **Ground (yellow-green)**

L → **LINE (brown or black)**

N → **Neutral (blue)**



### **WARNING:**

Be sure to that AC power source is disconnected before attempting to hardwire it to the unit.

4. Then, insert AC output wires according to polarities indicated on terminal block and tighten terminal screws.  
Be sure to connect PE protective conductor (⊕) first.

⊕ → **Ground (yellow-green)**

L → **LINE (brown or black)**

N → **Neutral (blue)**

5. Make sure the wires are securely connected.

**CAUTION:** Important

Be sure to connect AC wires with correct polarity. If L and N wires are connected reversely, it may cause utility short-circuited when these inverters are worked in parallel operation.

**CAUTION:** Appliances such as air conditioner are required at least 2~3 minutes to restart because it's required to have enough time to balance refrigerant gas inside of circuits. If a power shortage occurs and recovers in a short time, it will cause damage to your connected appliances. To prevent this kind of damage, please check manufacturer of air conditioner if it's equipped with time-delay function before installation. Otherwise, this inverter/charger will trig overload fault and cut off output to protect your appliance but sometimes it still causes internal damage to the air conditioner.

### AC Input Socket

There is a AC input socket for 3KW model. Directly connect a grid socket and AC input socket with mains input line. The battery will be charged.

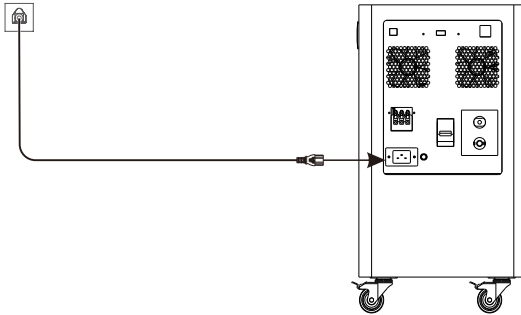

### AC Output Socket

There are 4 AC output sockets in the front for both 3KW and 5.2KW model. You can directly take AC power from AC output sockets.

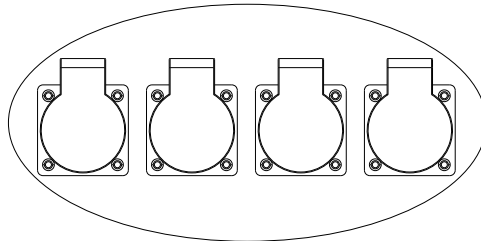

### PV Connection

#### PV Module Selection

When selecting proper PV modules, please be sure to consider below parameters:

1. Open circuit Voltage (Voc) of PV modules not exceeds max. PV array open circuit voltage of inverter.
2. Open circuit Voltage (Voc) of PV modules should be higher than min. battery voltage.
3. Max. Power Voltage (Vmpp) of PV modules should be close to best Vmp of inverter or within Vmp range to get best performance. If one PV module can not meet this requirement, it's necessary to have several PV modules in series connection. Refer to below table.

**Note:**\* Vmp: panel max power point voltage.

The PV charging efficiency is maximized while PV system voltage is close to Best Vmp.

**Maximum PV module numbers in Series:**  $V_{mpp}$  of PV module \* X pcs = Best  $V_{mp}$  of Inverter or  $V_{mp}$  range

**PV module numbers in Parallel:** Max. charging current of inverter /  $I_{mpp}$

**Total PV module numbers = maximum PV module numbers in series \* PV module numbers in parallel**

MODEL	3KW DC24V	5.2KW DC48V
Max. PV Array Open Circuit Voltage	160Vdc	450Vdc
PV Array MPPT Voltage Range	30-128Vdc	150-430Vdc
MPPT Number	1	

### PV Panel Connection

**CAUTION:** Before connecting to PV modules, please install separately a DC circuit breaker between unit and PV modules.

**WARNING!** All wiring must be performed by a qualified personnel.

**WARNING!** It's very important for system safety and efficient operation to use appropriate cable for PV module connection. To reduce risk of injury, please use the proper recommended cable size as below.

Model	Typical Amperage	Cable Size	Torque
5.2KW DC48V	27A	10AWG	1.2 ~ 1.6 Nm
3KW DC24V	18A	12AWG	

### MC4 Connector

For 3KW models, connect PV panel to the UNIT through the MC4 PV input port.

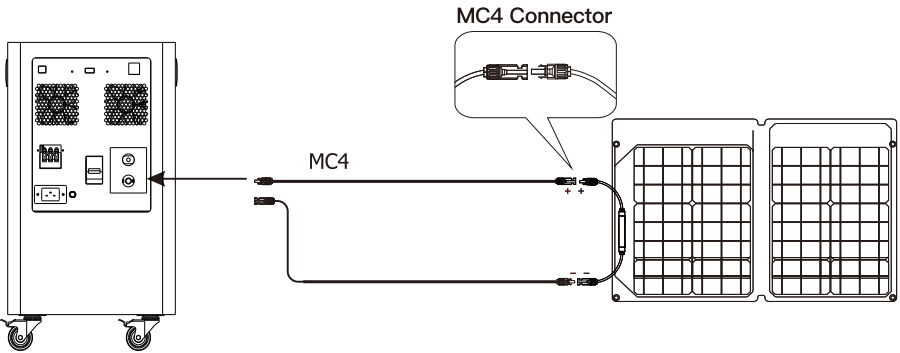

### PV Terminal Block

For 5.2KW models, please follow below steps to implement PV module connection:

Step 1 Remove insulation sleeve 10mm for positive and negative conductors.

Step 2 Check correct polarity of connect positive pole(+) of connection cable to positive pole(+) of PV input terminal. Connect negative pole(-) of connection cable to negative pole(-) of PV input terminal.

Step 3 Make sure the wires are securely connected.

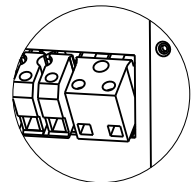
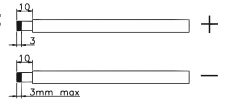

## Dry Contact Signal

There is one dry contact (3A/250VAC) available on the rear panel. It could be used to deliver signal to external device when battery voltage reaches warning level.

Unit status	Condition		Dry contact port:		
			NC&C	NO&C	
Power Off	Unit is off and no output is powered.		Close	Open	
Power On	output is powered from Utility		Close	Open	
	Output is powered from Battery or Solar.	Program 01 set as utility	Battery voltage<Low DC warning voltage	Open	Close
			Battery voltage>Setting value in Program 21	Close	Open
	Program 01 is set as SBU, SUB, solar first		Battery voltage<Setting value in Program 20	Open	Close
		Battery voltage>Setting value in Program 21	Close	Open	

## Upper Computer Communication

Please use the supplied USB communication cable to connect the device and PC through the USB-A communication port.

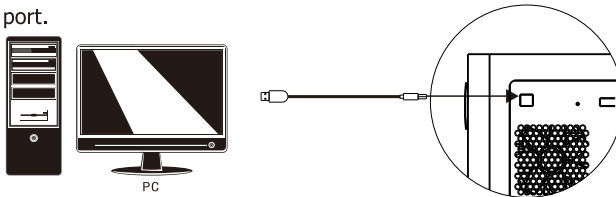

Download the software by link on the cover of this manual into PC and follow instruction on screen to install the monitoring software.

For the detailed software operation, please consult the seller if you have any questions.

**SolarflowMonitor**

Sp1000

Clear accumulated data  
Reset the parameter

AppParameters PortSetting Themes Logout Help

Ports:

- COM1-Device
- COM1 Working
- Scan
- Diagnose
- Sp1000

**Charger message:**

Work status	Work_Ma
Magt state	Current li
Charging state	Absorb ch
PV voltage	97.9 V
Battery voltage	27.2 V
Current	60.1 A
Power	16.38 W
Radiator temp	52 °C
External temp	0 °C
Battery Relay	Connect
PV Relay	Connect
Invert(V) Grade	74 V
Rated Current	50 A
ACCUM power	35.400Wh

**Inverter message:**

Work state	DRIVE	AC radiator temp	31 °C
AC voltage grade	230 V	Transformer temp	38 °C
Rated power	3000 W	DC radiator temp	0 °C
Battery voltage	27.3 V	Inverter relay status	Connect
Inverter voltage	229.7 V	Grid relay state	Disconn
Grid voltage	0 V	Load relay state	Connect
BUS voltage	424.2 V	ACCUM charge	0kWh
Control current	0 A	ACCUM discharge	58.68Wh
Inverter current	6.4 A	ACCUM buy	15.48Wh
Grid current	0 A	ACCUM sell	0kWh
Load current	6.2 A	ACCUM load	58.26Wh
Pf inverter	0.94	ACCUM self use	58.68Wh
Pf grid	0.94	ACCUM PV_sell	0kWh
Pf load	0.94	ACCUM grid_charge	11.68Wh
Load percent	2.1%	Batt power	-1294 W
Stemeter	88 VA	Batt current	59 A
Stand	0 VA	Inverter Hz	50 Hz
Stop	0 VA	Grid Hz	0 Hz

**Device Info**

The type of machine	PC1500
Hardware version(Inverter)	1.01.01
Software version(Inverter)	2.25.34
Hardware version(Charger)	1.01.02
Software version(Charger)	1.01.09
Firmware Edition	1.01.04

## OPERATION

Before turning on the device, please reserve a distance of more than 300mm above the device and 200mm to the left and right to ensure for heat dissipation, To ensure the best operation, the ambient temperature should be between 0-50 ° C.

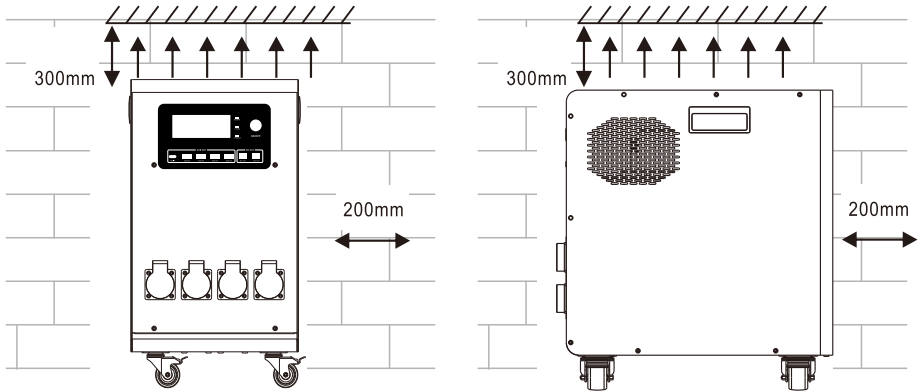

## Operation and Display Panel

The operation and display panel shown as below includes 3 LED indicators ,a ON/OFF switch and a LCD display, indicating the operation status of device.

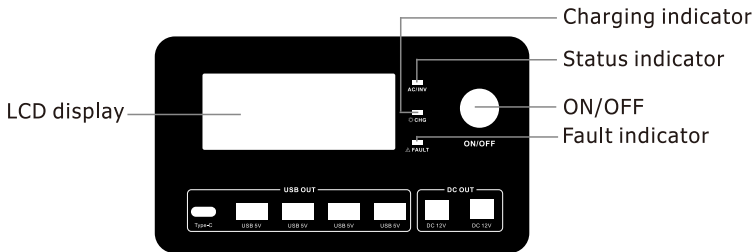

## LED Indicator

LED Indicator		Messages	
AC/ INV	Green	Solid ON	Output is powered by grid in Line mode.
		Flashing	Output is powered by battery or PV in battery mode.
CHG	Yellow	Flashing	Battery is recharging.
Δ FAULT	Red	Solid ON	Fault occurs in the device.
		Flashing	Warning condition occurs in the device.

## LCD Display Icons

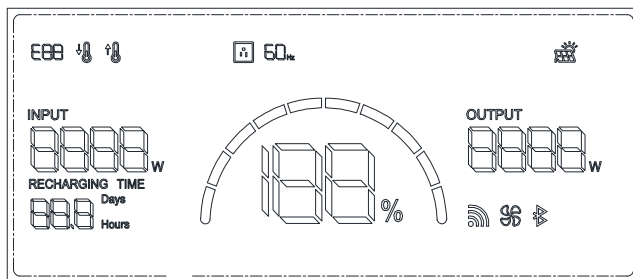

## LED Indicator

Icon	Description
	AC Input - The device has connected to the mains.
	PV Input - The device has connected to the PV panel.
	Output Frequency - Indicates output frequency (50/60Hz) of the device.
	Error code - Indicates the error occurred inside the device.
	Low Temperature Warning - The internal temperature of the battery is lower than the warning temperature.
	High Temperature Warning - The internal temperature of the battery is higher than the warning temperature.
	Input Power - Indicates the total input power including AC input and PV input.
	Output Power - Indicates the AC load power.
	Battery Power Percentage - Indicates the real-time percentage of the battery, and the 10- bar lights indicate the power of 5%,15%,25%,35%,45%,55%, 65%,75%,85%,95%.
	Recharging Time - When the battery is recharging , this icon will display.
	Remaining Time - When the battery is discharging, this icon indicates the remaining usage time under current load condition. When the battery is recharging, this icon indicates the recharging time under current charging condition.

## Power ON/OFF

Please close the battery breaker on the back firstly, then the device could be turned on by pressing the ON/OFF switch located on the front

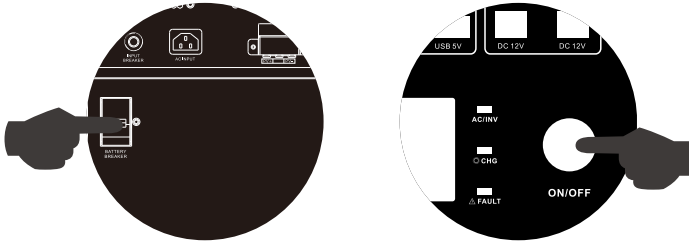

## Input and Output

1. DC output is powered without turning on the device.
2. After turning on, you can directly take power from the AC output sockets.
3. Use the supplied mains input line to connect the grid and the AC input socket to charge the battery from the mains.
4. Try not to move the device while it is running.

## Monitoring

Please use the supplied USB communication cable to connect the device and PC.

Download the software by link on the first page of this manual into PC and follow instruction on screen to install the monitoring software.

For the detailed software operation, please consult the seller if you have any questions.

Device Info	
The type of machine	
Hardware version(Inverter)	1.01.01
Software version(Inverter)	2.25.34
Hardware version(Charger)	1.01.02
Software version(Charger)	1.01.09
Protocol Edition	1.04.14

Charger message	
Work state	Work Mo
Mopt state	Current li
Charging state	Absorb cl
PV voltage	97.9 V
Battery voltage	27.2 V
Current	60.1 A
Power	1638 W
Radiator temp	57 °C
External temp	0 °C
Battery Relay	Connect
PV Relay	Connect
BattVol Grade	24 V
Rated Current	60 A
ACCUM power	36.4KWH

Inverter message	
Work state	OffGrid
AC voltage grade	230 V
Rated power	3000 W
Battery voltage	27.3 V
Inverte voltage	229.7 V
Grid voltage	0 V
BUS voltage	424.2 V
Control current	0 A
Inverter current	0.4 A
Grid current	0 A
Load current	0.3 A
PIInverter	54 W
PGrid	0 W
PLoad	0 W
Load percent	2 %
SInverter	88 VA
SGrid	0 VA
Sload	0 VA
AC radiator temp	31 °C
Transformer temp	36 °C
DC radiator temp	0 °C
Inverter relay state	Connect
Grid relay state	Disconn
Load relay state	Connect
ACCUM charge	0KWH
ACCUM discharge	58.6KA
ACCUM buy	15.4KA
ACCUM sell	0KWH
ACCUM load	59.2KA
ACCUM self use	58.6KA
ACCUM PV_sell	0KWH
ACCUM grid_charge	11.6KA
Batt. power	-1534 W
Batt. current	-59 A
Inverter Hz	50 Hz
Grid Hz	0 Hz

## Parameters Modification

**WARNING!** Please refer to the manual carefully or consult our professionals before modifying the device parameters, to prevent performance degradation or device failure.

Following these steps for parameters modification:

1. Click Login icon on the top bar, then enter password to enter PowerUser Mode.

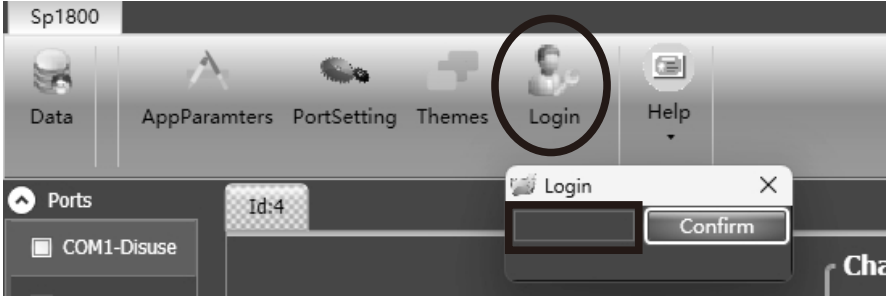

2. The top bar will change shown as below, click Inverter icon to open parameters setting window.

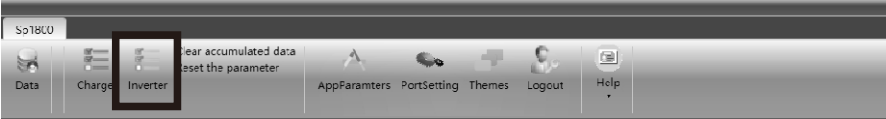

3. The parameters setting window is shown as below. After modification, click Confirm and wait for 15 seconds, repeat last step to check if the parameters are modified successfully.

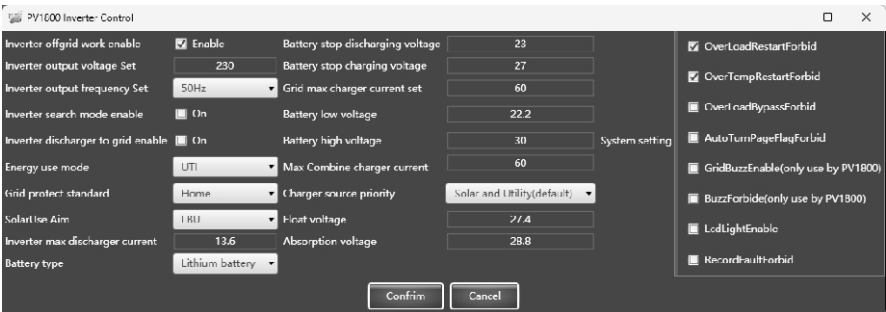

**WARNING!** Do Not modify any parameters other than following.

Program	Optional	
Inverter output voltage Set	230(default)	Set the output voltage amplitude(220Vac-240Vac)
Inverter output frequency Set	50Hz(default)	60Hz
Energy use mode	UTI(default)	Utility will provide power to the loads as first priority. Solar and battery energy will provide power to the loads only when utility power is not available.
	SBU	Solar energy provides power to the loads as first priority. If battery voltage has been higher than 27V for 5 minutes, the inverter will turn to battery mode, solar and battery will provide power to the load at the same time. When the battery voltage drops to 23V, the inverter will turn to bypass mode, utility provides power to the load only, and the solar will charge the battery at the same time.
	SOL	Solar energy provides power to the loads as first priority. If battery voltage has been higher than 27V for 5 minutes, and the solar energy has been available for 5 minutes too, the inverter will turn to battery mode, solar and battery will provide power to the load at the same time. When the battery voltage drops to 23V, the inverter will turn to bypass mode, utility provides power to the load only, and the solar will charge the battery at the same time.
Grid protect standard	Home(default)	If selected, acceptable AC input voltage range will be within 90-280VAC.
	VDE4105	If selected, acceptable AC input voltage range will conform to VDE4105(184-253VAC).
	UPS	If selected, acceptable AC input voltage range will be within 170-280VAC.
	GEN	When the user uses the device to connect the generator, select the generator mode.

## Fault Reference Code

Fault Code	Fault Event	Icon on
01	Fan is locked when inverter is off	E01
02	Inverter transformer over temperature	E02
03	battery voltage is too high	E03
04	battery voltage is too low	E04
05	Output short circuited	E05
06	Inverter output voltage is high	E06
07	Overload time out	E07
08	Inverter bus voltage is too high	E08
09	Bus soft start failed	E09
11	Main relay failed	E11
21	Inverter output voltage sensor error	E21
22	Inverter grid voltage sensor error	E22
23	Inverter output current sensor error	E23
24	Inverter grid current sensor error	E24
25	Inverter load current sensor error	E25
26	Inverter grid over current error	E26
27	Inverter radiator over temperature	E27
31	Solar charger battery voltage class error	E31
32	Solar charger current sensor error	E32
33	Solar charger current is uncontrollable	E33
41	Inverter grid voltage is low	E41

42	Inverter grid voltage is high	E42
43	Inverter grid under frequency	E43
44	Inverter grid over frequency	E44
51	Inverter over current protection error	E51
52	Inverter bus voltage is too low	E52
53	Inverter soft start failed	E53
55	Over DC voltage in AC output	E55
56	Battery connection is open	E56
57	Inverter control current sensor error	E57
58	Inverter output voltage is too low	E58
98	BMS communication error	E98
99	Inverter communication error	E99

### Warning Indicator

Fault Code	Fault Event	Icon on
61	Fan is locked when inverter is on.	E61
62	Fan 2 is locked when inverter is on.	E62
63	Battery is over-charged.	E63
64	Low battery.	E64
67	Overload.	E67
70	Output power derating.	E70
72	Solar charger stops due to low battery.	E72
73	Solar charger stops due to high PV voltage.	E73
74	Solar charger stops due to over load.	E74
75	Solar charger over temperature.	E75
76	PV charger communication error.	E76
77	Parameter error.	E77

## TROUBLE SHOOTING

Problem	LCD/LED/Buzzer	Explanation / Possible cause	What to do
Unit shuts down automatically during startup process.	LCD/LEDs and buzzer will be active for 3 seconds and then complete off.	The battery voltage is too low	1. Re-charge battery. 2. Return to repair center.
No response after power on.	No indication.	1. The battery voltage is far too low. 2. Battery polarity is connected reversed. Input protector is tripped	1. Check if the battery breaker is ON. 2. Re-charge battery. 3. Return to repair center.
Mains exist but the unit works in battery mode.	Input voltage is displayed as 0 on the LCD and green LED is flashing.	Input protector is tripped	Check if AC breaker is tripped and AC wiring is connected well.
	Green LED is flashing.	Insufficient quality of AC power (Shore or Generator)	1. Check if AC wires are too thin and/or too long. 2. Check if generator (if applied) is working well or if input voltage range setting is correct.(Appliance=>wide)
When the unit is turned on, internal relay is switched on and off repeatedly.	LCD display and LEDs are flashing	Battery is disconnected.	Check if the battery breaker in ON.
Buzzer beeps continuously and red LED is on.	Fault code 07	Overload error. The inverter is overload 110% and time is up.	Reduce the connected load by switching off some equipment.
	Fault code 05	Output short circuited.	Check if wiring is connected well and remove abnormal load.
	Fault code 02	Internal temperature of inverter component is over 90oC.	Check whether the air flow of the unit is blocked or whether the ambient temperature is too high.
	Fault code 03	Battery is over-charged.	Return to repair center.
		The battery voltage is too high.	Check if spec and quantity of batteries are meet requirements.
	Fault code 01	Fan fault	Replace the fan.
	Fault code 06/58	Output abnormal (Inverter voltage below than 202Vac or is higher than 253Vac)	1. Reduce the connected load. 2. Return to repair center
	Fault code 08/09/53/57	Internal components filed.	Return to repair center
	Fault code 51	Over current or surge	Restart the unit, if the error happens again, please return to repair center.
	Fault code 52	Bus voltage is too low	
Fault code 55	Output voltage is unbalanced		
Fault code 56	Battery is not connected well or fuse is burnt.	If the battery is connected well, please return to repair center.	

## SPECIFICATIONS

		3024	5248	
INVERTER OUTPUT	Rated power	3000W	5200W	
	Output Waveform	Pure Sine Wave		
	Output voltage	230V $\pm$ 5%		
	Output frequency	50Hz / 60Hz ( $\pm$ 0.2Hz)		
	Peak efficiency	90%		
	Standby Consumption	< 25W		
PV Input	Max charging current	60A ( $\pm$ 3A)	100A ( $\pm$ 3A)	
	Max combined charging current	120A ( $\pm$ 4A)	120A ( $\pm$ 4A)	
	Max efficiency	98% max		
	PV array open circuit voltage	160VDC	450VDC	
	PV Array MPPT Voltage Range	30~128V	150~430V	
AC Input	AC input voltage	230Vac $\pm$ 5%		
	Input voltage range	90-280VAC		
	Nominal input frequency	50Hz / 60Hz (Auto detection)		
	Transfer time	10ms typical (UPS, VDE); 20ms typical (APL)		
	Max AC Charging current	30A ( $\pm$ 4A)	40A ( $\pm$ 4A)	
DC Output	USB 5V	4PCS (5V 2A)		
	12V	2PCS (12V 1A)		
	Type-c	1PCS (5V 2A)		
Lithium Battery	Nominal voltage	25.6V	51.2V	
	Battery capacity	120Ah/3200Wh	100Ah/5120Wh	
	Rated discharge current	140A	100A	
	Operation temperature	Charge	0°C to 45°C	
		Discharge	-10°C to 60°C	



**MUST**<sup>®</sup>

# GUARANTEE CERTIFICATE

Serial No.: \_\_\_\_\_

Customer's Name				Contact Person	
Address				Telephone No.	
Product/Model:		Post Code		Fax No.	
Date of purchase			Expire Date		
Dealer Signature			Customer Signature		

**MUST**<sup>®</sup>

# GUARANTEE CERTIFICATE

Serial No.: \_\_\_\_\_

Customer's Name				Contact Person	
Address				Telephone No.	
Product/Model:		Post Code		Fax No.	
Date of purchase			Expire Date		
Dealer Signature			Customer Signature		