

# **HAHN** **& SOHN**

## H IG 9500

QUIET INVERTER PETROL GENERATOR

User Manual

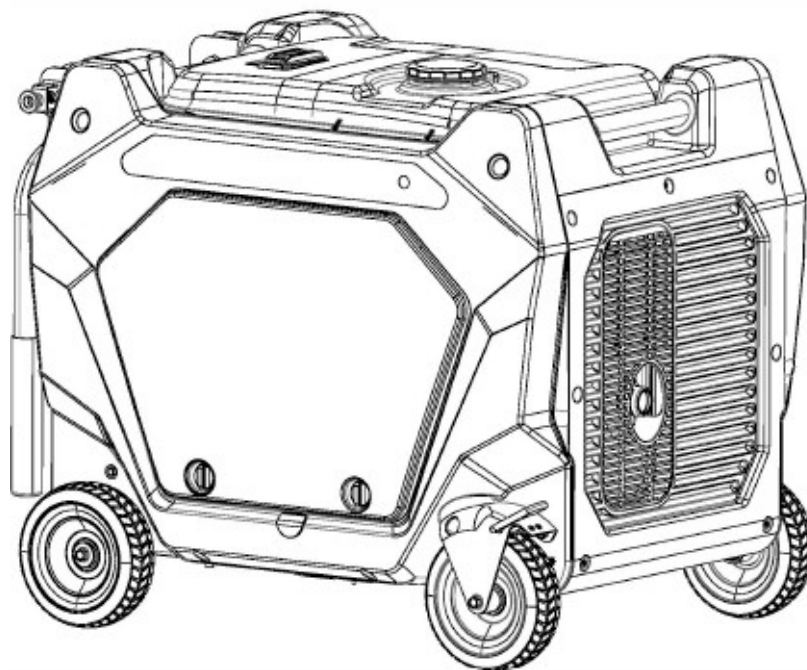

Thank you for choosing our company's silent inverter generator.

All information in this publication is based on the latest product information available at the time of printing. The contents of this manual may differ from the actual parts due to revisions and other changes.

Our company reserves the right to make changes at any time without prior notice and without any obligation. No part of this publication may be reproduced without the written consent of our company.

This manual should be regarded as a permanent part of the generator and should be included with the generator in the event of its resale.

Contents

**SAFETY WARNINGS** ..... **4**

**SAFETY INFORMATION** ..... **5**

**DESCRIPTION** ..... **8**

**CONTROL FUNCTIONS** ..... **9**

**PREPARATION** ..... **13**

**OPERATION** ..... **15**

**MAINTENANCE** ..... **19**

**STORAGE** ..... **25**

**TROUBLESHOOTING** ..... **27**

**TECHNICAL SPECIFICATIONS** ..... **28**

**HOW TO CONNECT THE BATTERY** ..... **29**

**FUEL SELECTION** ..... **30**

## **SAFETY WARNINGS**

- Your personal safety and the safety of your property and that of others are of the utmost importance.
- Please read these instructions carefully; they are marked with the symbol  or the note "WARNING".

### **DANGER**

Failure to follow the instructions will **RESULT IN DEATH** or **SERIOUS INJURY**.

### **WARNING**

**YOU COULD LOSE YOUR LIFE** or **SUFFER SERIOUS INJURY** if you do not follow the instructions.

### **CAUTION**

**YOU MAY INJURE YOURSELF** if you do not follow the instructions.



### **WARNING**

Your generator or other property could be damaged if you do not follow the instructions.



# SAFETY INFORMATION



Before putting the generator into operation, read this operating manual carefully and ensure that you understand it.

Familiarising yourself with the procedures for safe operation of the generator will help you prevent accidents.

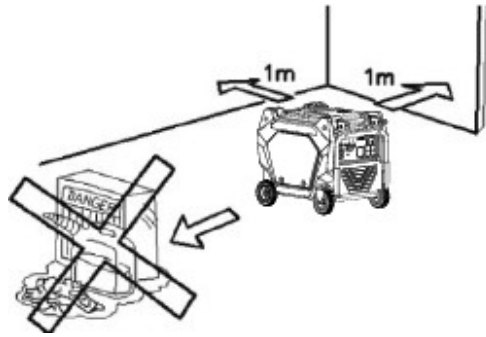
	
<p>Never use it indoors</p>	<p>Never use it if it is wet</p>

<p>Never connect it directly to the mains</p>

	
<p>Keep it at least 1 m away from flammable materials</p>	<p>Never smoke whilst refuelling</p>

	
<p>Do not spill fuel whilst refuelling</p>	<p>Switch off the engine before refuelling</p>

### Connection to the domestic mains supply

#### WARNING

- If the generator is to be connected to the domestic mains supply as a backup power source, the connection must be carried out by a qualified electrician or a person with the appropriate electrical knowledge.
- When connecting loads to the generator, carefully check that the electrical connections are safe and secure. Any incorrect connection may cause damage to the generator or a fire.

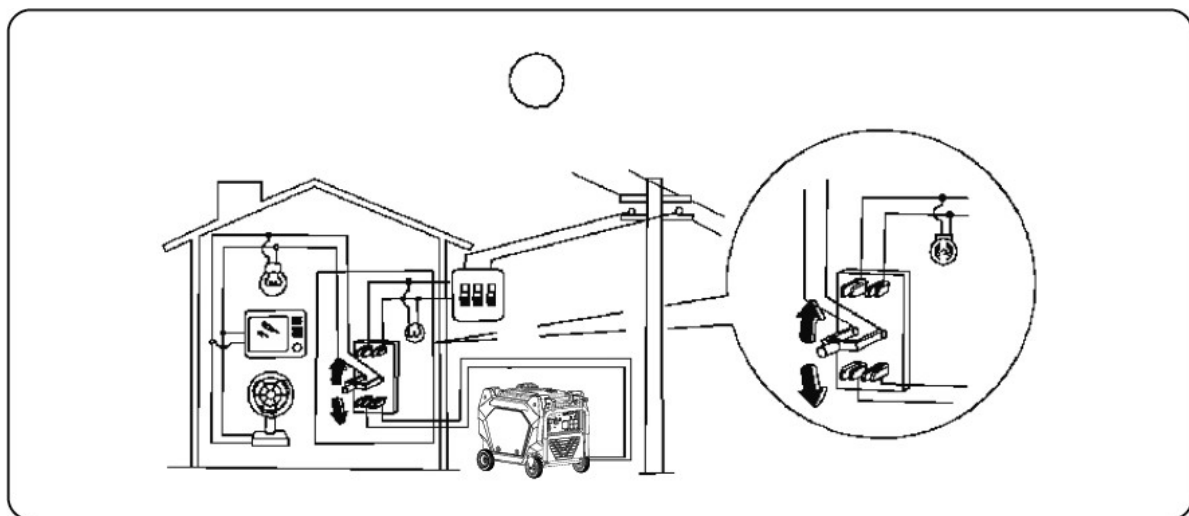
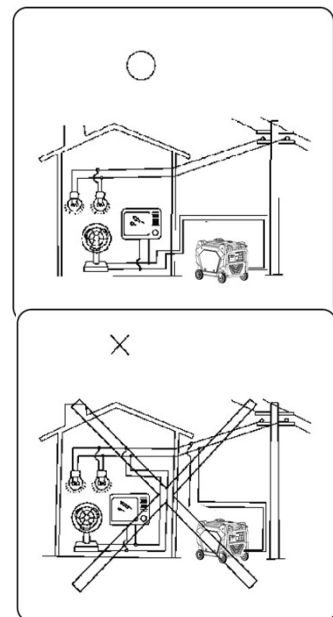

## Earthing the generator

To prevent electric shock caused by faulty electrical appliances or incorrect handling of electricity, the generator must be earthed using a high-quality insulated conductor.

### **WARNING**

- Ensure that the control panel, grille and underside of the inverter are well ventilated and that no chips, mud or water can enter them. Blocking the cooling vent may result in damage to the engine, inverter or the alternator.
- When transporting, storing or operating the generator, do not store it together with other objects.
- Fluid leakage from the generator may cause damage to the generator or pose a risk to property.

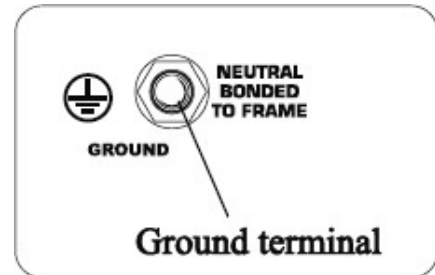

## DESCRIPTION

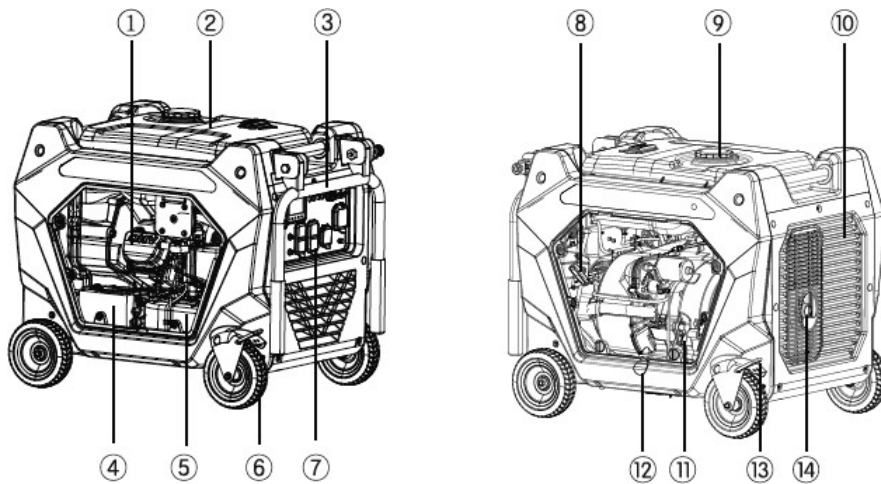

1. Spark plug	8. Starter
2. Fuel tank	9. Fuel tank cap
3. Carrying handle	10. Grille
4. Battery	11. Oil filler cap
5. Air filter	12. Oil drain hose
6. Wheel	13. Wheel lock
7. Control panel	14. Silencer

### Control panel

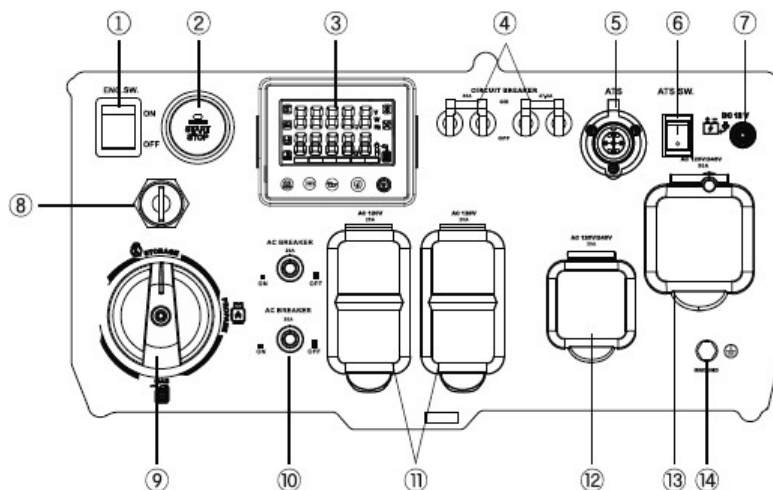

1. Power switch	8. Power connection
2. Electric starter	9. Fuel switch
3. Digital display	10. AC circuit breaker
4. Circuit breakers	11. 20 A AC socket

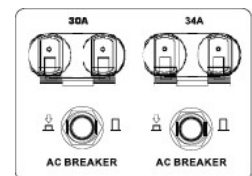
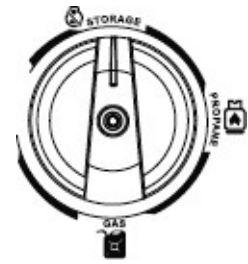
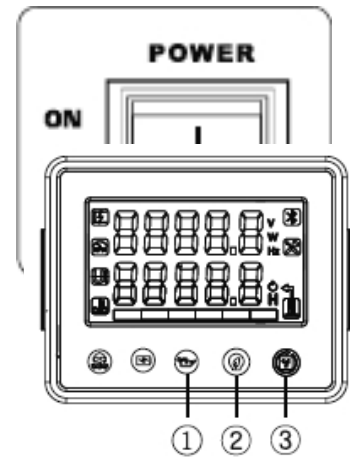

5. ATS	12. 30 A AC socket
6. ATS switch	13. 50 A AC socket
7. Charging plug	14. Earth terminal

## CONTROL FUNCTIONS

### Power switch

Before starting the device, the power switch ① must be set to the “ON” position.

The power switch ① is the generator’s main switch. If switch ① is in the ‘OFF’ position, no operations performed on the device will take effect.

**Tip:**

The power switch can be used as an emergency switch if necessary.

**Fuel switch**

- ① Set the fuel switch to the “PROPANE” position; connect the propane.
- ② Switch the fuel selector to the “GAS” position; use petrol.

**Electric start/stop button**

Press the engine switch to start the engine. Press the engine switch again to stop the engine.

**Circuit breakers**

The circuit breakers are designed to protect the generator.

Switch all circuit breakers to the “ON” position before connecting any electrical equipment to the generator. The circuit breakers will automatically switch to the “OFF” position if the rated current is exceeded whilst electrical equipment is connected. To use the equipment again, switch all circuit breakers to the “ON” position.

If a circuit breaker switches automatically to the ‘OFF’ position, check the load status before switching it back to ‘ON’.



If the circuit breaker trips, reduce the load on the connected electrical equipment to below the generator’s rated power. If the circuit breaker trips again, stop using the equipment immediately and contact an authorised dealer of our company.

**Digital display**

- ① Oil level indicator
- ② ECO control
- ③ Operation indicator and reset button

**1. ECO control**

Pressing the ECO control ① activates ECO mode; the unit then regulates the engine speed according to the connected load. This results in lower fuel consumption and reduced noise levels.

If ECO mode is switched off (“OFF”), the engine runs at rated speed regardless of whether a load is connected.

**Tip:**

ECO mode should not be used when operating electrical equipment that requires a high current, such as a compressor or a submersible pump.

## 2. Oil warning light (red)

If the oil level falls below the lower limit, the oil warning light ② will come on and the engine will stop automatically. Unless you top up the oil, the engine will not start again.

**Tip:**

If the engine cuts out or fails to start, switch the engine switch to the “ON” position and then pull the starter cord. If the oil warning light flashes for a few seconds, this indicates that there is insufficient oil in the engine. Top up the oil and try starting again.

## 3. Operation indicator light and reset button

The operation indicator ③ lights up (green) when the engine starts and begins to generate power.

The operation indicator ③ will light up red if an overload is detected in the connected electrical equipment, the inverter control unit overheats, or the AC output voltage rises. The AC protection will then be activated, stopping power generation to protect the generator and all connected electrical equipment.

The operation indicator ③ will light up red and power generation will stop, but the engine will continue to run. Press the reset button and the generator will reset to its rated output; the indicator will light up green.

If the reset button does not work, please proceed as follows:

1. Switch off all connected electrical appliances and stop the engine (press the electric start/stop switch to stop the engine)
2. Reduce the total power consumption of the connected electrical devices to below the rated power
3. Check that the cooling air intake and the area around the control unit are not blocked. If you find any blockages, remove them
4. After checking, restart the engine.



## 4. Switching between display modes

The multimeter can display voltage, power, operating hours, and oil level. Press button ④ to switch between the different readings.

### CO sensor

The CO indicator light will not illuminate if the carbon monoxide concentration is within the normal range.

If the CO indicator flashes red: dangerous concentrations of carbon monoxide have accumulated. Leave the area immediately and wait until it has been ventilated. Before starting the generator, move it to a well-ventilated area.

If the CO indicator light flashes yellow: fault with the carbon monoxide sensor. The sensor needs to be repaired.

### **Earth terminal**

The earth terminal connects the earth conductor to prevent electric shock. If the electrical equipment is earthed, the generator must always be earthed as well.

### **ATS**

1. Before using the ATS function, set the ATS switch to the “ON” position.
2. To control the starting and stopping of the generator, connect the equipment to the ATS control box using the cable harness.

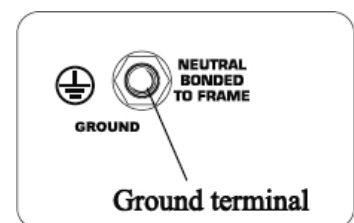

## PREPARATION

### Fuel

#### DANGER

- Fuel is highly flammable and toxic. Read the “SAFETY INFORMATION” carefully before refuelling.
- Do not overfill the fuel tank, as this may cause it to overflow when the fuel heats up and expands.
- After refuelling, ensure that the fuel cap is securely tightened.

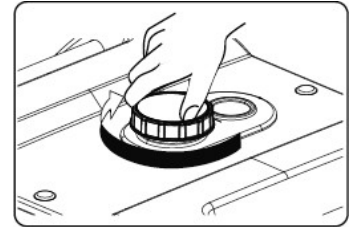

#### WARNING

- Wipe up any spilled fuel immediately with a clean, dry, soft cloth, as fuel can damage painted surfaces or plastic parts.
- Use unleaded petrol only. Using leaded petrol will cause serious damage to the engine’s internal components.

Remove the fuel cap and fill the tank up to the red line ①. Recommended fuel: unleaded petrol

Fuel tank capacity: 33 l

- If the fuel filter screen is not marked, the oil level is measured from the edge of the oil sump at a height of 25.4 mm;
- If the fuel filter is marked, the fuel volume is added to this mark.

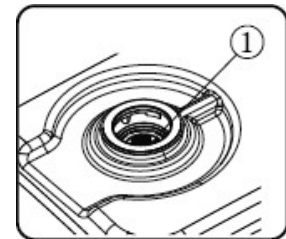

### Engine oil

#### WARNING

The generator has been supplied without engine oil. Do not start the engine until you have filled it with a sufficient quantity of engine oil.

1. Place the generator on a flat surface.
2. Unscrew the knobs ① on the right-hand service cover and remove it.
3. Unscrew the oil drain plug, then screw the plug into the filler hole and use a funnel to top up with the specified amount of oil.
4. Screw the filler cap back on, replace the service cover and screw the knobs ①.

Recommended engine oil: SAE 10W-30

Recommended engine oil grade: API Service SJ or higher Engine oil

capacity: 1.2 l

### CHECKS BEFORE STARTING

#### WARNING

- If any item on the pre-startup checklist is not working properly, have it checked and repaired before putting the generator into operation.
- The generator owner is responsible for the condition of the generator. Key components can start to wear out quickly and unexpectedly, even when the generator is not in use.

**TIP:** A pre-start check must be carried out every time the generator is used.

#### **Pre-start check Fuel**

- Check the fuel level in the tank.
- Top up the fuel if necessary.

#### **Engine oil**

- Check the engine oil level.
- If necessary, top up with the recommended oil to the specified level.
- Check that there are no oil leaks from the generator.

#### **If a fault is detected**

- Check the operation.
- If necessary, top up with the recommended oil to the specified level.
- If necessary, please contact one of our authorised dealers.

## OPERATION

### ⚠ WARNING

- Never use the engine in an enclosed space, as this could quickly lead to loss of consciousness and death. Operate the engine in a well-ventilated area.
- Do not connect any electrical equipment before starting the engine.

### NOTICE

- The generator has been supplied without engine oil. Do not start the engine until you have added a sufficient quantity of engine oil.
- Do not tilt the generator when topping up the engine oil. This could cause overfilling and damage the engine.

### TIP:

- The generator can be used with a rated output load under standard atmospheric conditions.
- “Standard atmospheric conditions”
- Ambient temperature 25 °C
- Barometric pressure 100 kPa
- Relative humidity 30%
- The generator’s output varies depending on temperature, altitude (lower air pressure at higher altitudes) and humidity.
- The generator's output decreases if the temperature, humidity and altitude are higher than standard atmospheric conditions.
- Furthermore, when used in enclosed spaces, the load must be reduced, as this affects the generator’s cooling.

### Starting the engine

Before handling the unit in any way, ensure that the fuel and oil tanks are full. If the mains supply is earthed, ensure that the generator is also earthed before starting the engine.

1. Turn on the main switch ①

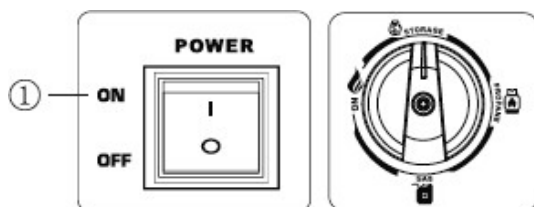

2. Open the fuel valve ②
3. Switch on all circuit breakers

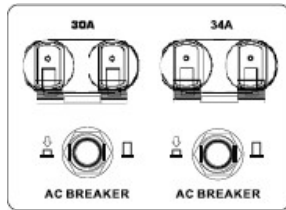

4. Start the engine. There are two options for starting the engine:

- a) Press the electric engine start/stop button ③

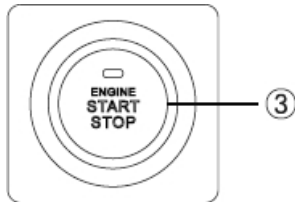

- b) Press the button on the remote control

If the engine cannot be started using the button, try starting it using the starter cord: Step 1:

Unscrew the knobs on the right-hand engine cover and remove it.

Step 2: Slowly pull the starter cord until it catches, then pull it sharply.

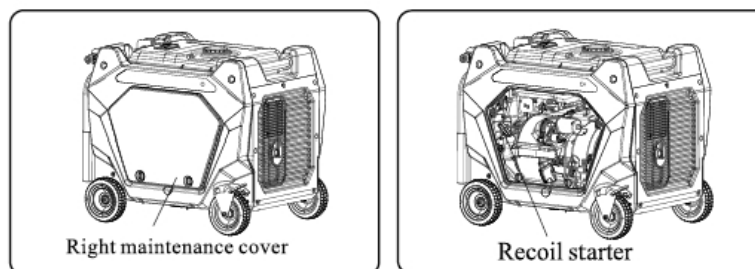

**TIP:** Hold the carrying handle firmly to prevent the generator from tipping over when pulling the starter cord.

### Stopping the engine

TIP: Switch off all electrical appliances.

1. Switch off ECO mode.
2. Disconnect all electrical appliances.
3. Set the switch to the "OFF" position.
  - a) The ignition circuit is switched off.
  - b) The fuel supply is shut off.

### Connecting to the mains (AC)

- Before connecting to the generator, ensure that all electrical equipment, including cables and connectors, is in good condition.
- Ensure that the total load is within the generator's rated power.

- Make sure that the current in the socket is within the socket's rated current.

**TIP:** Make sure the generator is earthed. If the electrical equipment is earthed, the generator must always be earthed as well.



1. Start the engine.
2. Set the ESC to the "ON" position.
3. Plug into a mains socket.
4. Make sure the power indicator light is on.
5. Switch on all electrical equipment.

**TIP:** To increase the engine speed to its rated speed, the ESC must be switched to the "OFF" position.

If the generator is connected to multiple loads or electrical appliances, remember to connect the one with the highest starting current first and the one with the lowest starting current last.

### Scope of use

When using the generator, ensure that the total load does not exceed the generator's rated power. Otherwise, the generator may be damaged.

	AC			
8kW	Power factor	1	0.8–0.95	0.4–0.75 (Efficiency 0.85)
	Rated output power	≤ 8,000 W	≤ 6,400 W	≤ 2,720 W
9 kW	Rated output power	≤ 9,000 W	≤ 7,200 W	≤ 3,060 W

**TIP:**

- The stated power consumption applies to the operation of individual devices separately.
- It is possible to use both AC and DC power simultaneously, but the total power consumption must not exceed the rated power.

Rated generator power		8.0 kW	9.0 kW
Frequency	Power factor	-	
AC	1.0	≤ 8,000 W	≤ 9,000 W
DC	---	100W (12V/8.3A)	

The overload indicator light will illuminate as soon as the total power consumption exceeds the permitted range. **WARNING**

- Do not overload the unit. The total power consumption of all electrical appliances must not exceed the generator's rated power. Overloading may damage the generator.
- When powering precision instruments, electronic control units, computers, electronic devices, microcomputer-based equipment or battery chargers, keep the generator at a sufficient distance to prevent electrical interference from the engine. Also ensure that electrical noise from the engine does not interfere with any other electrical equipment located near the generator.
- If the generator is to power medical equipment, you must first seek advice from the manufacturer, a medical professional or the hospital.
- Some electrical appliances or universal electric motors have high starting currents and therefore cannot be used, even if they fall within the power ranges specified in the table above. For further information, please contact the equipment manufacturer.

## MAINTENANCE

The engine must be properly maintained to ensure safe, economical and trouble-free operation, and to ensure it is environmentally friendly.

To keep your petrol engine in good working order, it must be serviced regularly. It is essential to follow the maintenance schedule and regular inspection procedures carefully:

Items		Frequency	Every time	First month or first 200 operating hours	Thereafter every 3 months or every 50 operating hours	Every year or every 1000 operating hours
Engine oil	Check – top up		X			
	Change			X	X	
Oil for the reduction gearbox (if fitted)	Check oil level		X			
	Change			X	X	
Air filter element	Check		X			
	Clean			X		
	Replace				X	
Collection container (if included)	Clean					X
Spark plug	Check – adjust					X
	Replace		Every year or after 250 operating hours			
Spark arrestor	Clean				X	
Idle speed (if fitted) *	Check – adjust					X
Valve clearance *	Check – adjust					X
Fuel tank and fuel filter *	Clean					X
Fuel lines	Check	Every 2 years (adjust if necessary)				
Cylinder head, piston	Clean soot*	< 225 cm <sup>3</sup> , every 125 hours ≥ 225 cm <sup>3</sup> , every 250 hours				

\*Maintenance and repairs to these components should be carried out by our authorised dealer if the owner does not have the appropriate tools and sufficient experience with mechanical maintenance.

#### WARNING

- If the petrol engine frequently operates at high temperatures or under heavy loads, change the oil every 25 hours.
- If the engine is frequently operated in a dusty environment or under other demanding conditions, clean the air filter every 10 hours; if necessary, replace the air filter every 25 hours.
- The maintenance interval or the exact time (hours) applies, whichever comes first.
- If you have missed the scheduled engine maintenance, have it carried out as soon as possible.

#### ! WARNING

Switch off the engine before carrying out maintenance.

Place the engine on a flat surface and remove the spark plug cap to prevent the engine from starting.

Do not use the engine in poorly ventilated rooms or other enclosed spaces. Ensure there is adequate ventilation in the work area. Engine exhaust fumes may contain toxic carbon monoxide (CO); inhaling them can cause shock, loss of consciousness and even death.

#### Checking the spark plugs

The spark plug is an important part of the engine and must be checked regularly.

1. Remove the cover ① and the spark plug cap ② and, from the outside of the cover, insert tool ③ into the hole from the outside of the cover. ④

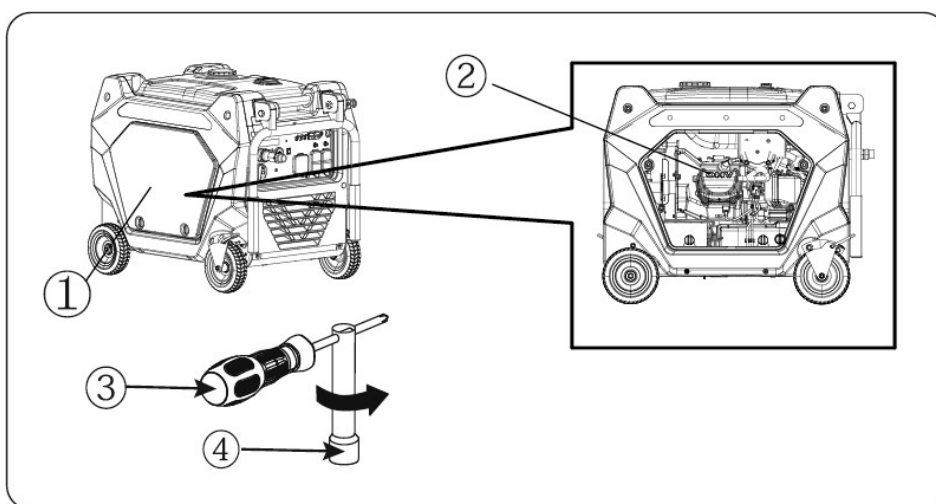

2. Insert the handle (3) into the tool (4) and turn it anti-clockwise to remove the spark plug.
3. Check that the spark plug is not discoloured and remove any deposits. The porcelain insulator around the spark plug's centre electrode should be a medium to light brown colour.

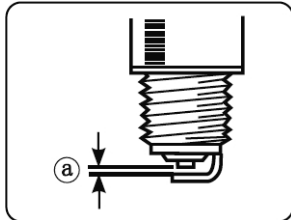

4. Check the type of spark plug and its gap.

Standard spark plug: F7RTC

Spark plug gap: 0.7–0.8 mm

**TIP:** The spark plug gap must be measured using a feeler gauge and adjusted to the specified value if necessary.

5. Fit the spark plug. Spark plug

tightening torque: 28 N·m

**TIP:** If you do not have a torque wrench available when fitting the spark plug, the correct tightening torque can be roughly estimated as 1/4–1/2 turn beyond hand-tight. However, the spark plug must be tightened to the specified torque as soon as possible.

6. Fit the spark plug cap and the ignition system cover.

### Carburettor adjustment

The carburettor is a key component of the engine. Its adjustment should be entrusted to an authorised dealer of our company, who possesses the expertise, specialist data and equipment required to carry it out correctly.

### Engine oil change



Do not drain the engine oil immediately after stopping the engine. The oil is hot and must be handled with care to avoid burns.

1. Place the generator on a flat surface and allow the engine to warm up for a few minutes. Then switch off the engine and turn the fuel switch knob and the fuel tank cap vent knob to the 'OFF' position.
2. Unscrew the bolts and remove the cover.
3. Remove the oil filler cap.
4. Place an oil collection container under the engine. Tilt the generator so that the oil drains out completely.

5. Change the engine oil on a level surface.

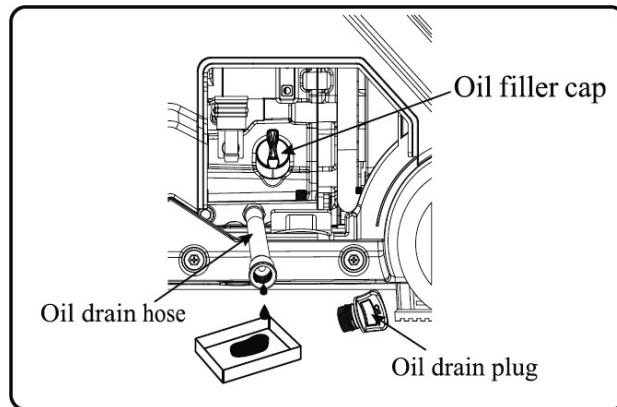
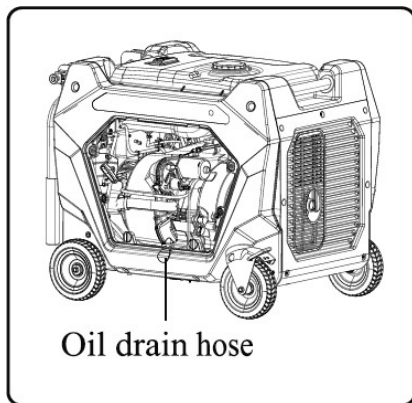

#### WARNING

Do not tilt the generator when topping up the engine oil. This could cause overfilling and damage the engine.

#### WARNING

Ensure that no foreign objects enter the crankcase.

1. Refit the oil filler cap.
2. Fit the cover and tighten the screws.

#### Air filter

1. Unscrew the bolts ① and then remove the cover ②.
2. Remove the air filter housing cover ③.
3. Remove the paper or foam filter.
4. Paper filter: Tap the filter lightly or blow it out from the inside using an air gun until all dirt has fallen out; do not use brushes. Foam filter: Use a mild detergent to clean. Once the filter is completely dry, apply a small amount of fresh oil to it so that Allow the oil to soak in, then squeeze out any excess oil.

The foam filter should be damp, but oil should not drip from it.

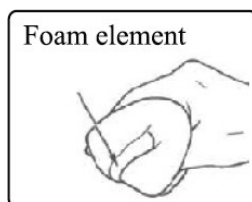

#### WARNING

Do not wring out the foam element when compressing it. This could cause it to tear.

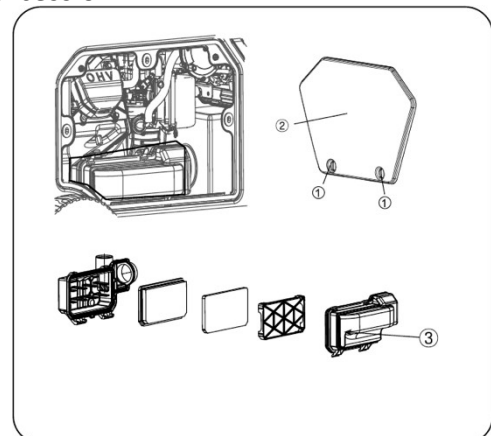

5. Insert the paper or foam filter into the air filter housing.

TIP: Ensure that the sealing surface of the foam element fits snugly against the air filter to prevent air leakage.

The engine should never be run without the foam element; this could cause excessive wear to the piston and cylinder.

6. Refit the air filter housing cover to its original position and tighten the screw.
7. Fit the cover and secure it.

### Exhaust cover and spark arrestor

#### WARNING

- The engine and exhaust will be very hot after the engine has been running.
- When inspecting or repairing, do not touch the engine or exhaust silencer with any part of your body or clothing until they have cooled down.

1. Unscrew the bolts ①.
2. Remove the exhaust silencer cover ②, the exhaust silencer grille ③ and the spark arrestor ④.
3. Remove carbon deposits from the exhaust silencer grille and spark arrestor using a wire brush.

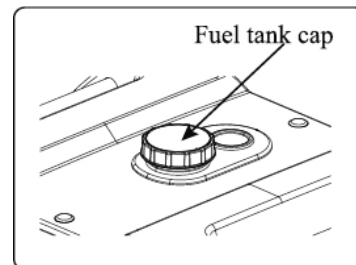

#### WARNING

When cleaning, use the wire brush with great care so as not to damage or scratch the exhaust silencer grille and spark arrestor.

4. Check the exhaust silencer grille and the spark arrestor. If they are damaged, replace them.
5. Fit the spark arrestor.

TIP: Align the protrusion on the spark arrestor with the hole in the exhaust silencer pipe.

6. Fit the exhaust silencer grille and the silencer cover.
7. Fit the cover and tighten the bolts.

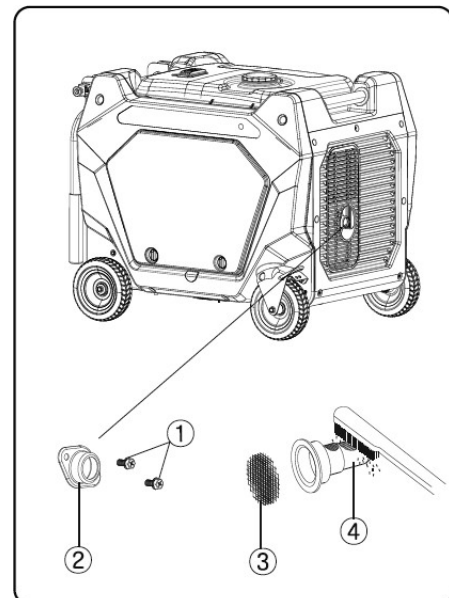

### Fuel tank filter

#### WARNING

Never use petrol whilst smoking or near an open flame.

1. Remove the fuel tank cap and the filter.
2. Clean the filter with petrol.

3. Wipe the filter and fit it.
4. Replace the fuel cap.

Make sure the fuel cap is tightened securely.

### Fuel filter

1. Unscrew the bolts ①, then remove the cover ② and drain the fuel.

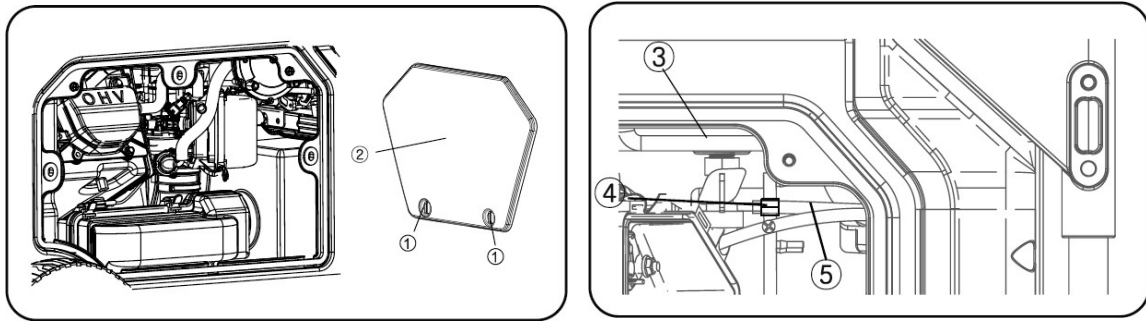

2. Hold clamp ④ and slide it upwards, then disconnect hose ⑤ from the tank.
3. Remove the fuel filter.
4. Clean the filter with petrol.
5. Dry the filter and reinsert it into the tank.
6. Refit the hose and clamp, then open the fuel valve to check for any fuel leaks.
7. Fit the cover and tighten the screws.

## STORAGE

Long-term storage of the machine requires certain precautions to prevent damage.

### Drain the fuel

1. Turn the switch knob to the “OFF” position.
2. Remove the fuel cap and take out the filter. Drain the fuel from the fuel tank into an approved petrol container. Then replace the fuel cap.

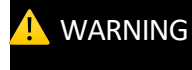

Fuel is highly flammable and toxic. Read the “SAFETY INFORMATION” carefully (see page 4).

### CAUTION

Wipe up any spilled fuel immediately with a clean, dry, soft cloth, as fuel can damage painted surfaces or plastic parts.

3. Start the engine (see page 18) and let it run until it stops of its own accord. The engine will stop after approximately 20 minutes. The time is measured from when the fuel runs out.

### TIP:

- Do not connect any electrical equipment. (no-load operation)
  - The engine running time depends on the amount of fuel remaining in the tank.
4. Unscrew the bolts and remove the cover.
  5. Drain the fuel from the carburettor by loosening the drain screw on the carburettor float chamber.
  6. Set the 3-in-1 switch to the “OFF” position.
  7. Tighten the drain screw.
  8. Refit the cover and tighten the screws.
  9. Once the engine has cooled down completely, turn the fuel tank cap vent knob to the “OFF” position.

### Engine

Follow these steps to protect the cylinder, piston rings, etc. from corrosion.

1. Remove the spark plug, pour approximately one tablespoon of SAE 10W-30 oil into the spark plug hole, and reinstall the spark plug. Start the engine using the starter cord by turning it a few times to coat the cylinder walls with oil.
2. Pull the starter cord until you feel resistance. Then stop pulling. (This will prevent corrosion of the cylinder and valves).
3. Clean the outside of the alternator. Store the alternator in a dry, well-ventilated place and cover it with a cover.



# TROUBLESHOOTING

## The engine will not start

### 1. Fuel systems

No fuel is being supplied to the combustion chamber.

- There is no fuel in the tank... Refuel.
- There is fuel in the tank... Turn the fuel cap vent knob and the fuel tap knob to the "ON" position
- Clogged fuel filter... Clean the fuel filter.
- Clogged carburettor... Clean the carburettor.

### 2. Engine oil system

Insufficient

- Low oil level... Top up the engine oil.

### 3. Electrical systems

- Set switch 1 of 3 to the 'CHOKE' position and pull the starter cord ... Weak spark.
- The spark plug is sooty or damp ... Clean off the soot or dry the spark plug.
- Fault in the ignition system ... contact an authorised dealer of our company.

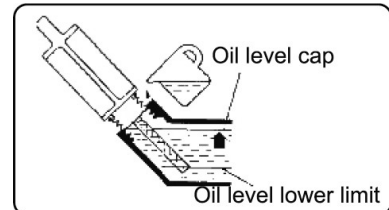

## The generator is not producing power

The circuit breaker (DC protection) is in the "OFF" position ... Switch the DC protection to the "ON" position.

The AC indicator light (green) has gone out ... Switch off the engine and then restart it.

## TECHNICAL SPECIFICATIONS

		8 kW	9 kW
Generator	Type	Silent Inverter	
	Rated frequency (Hz)	50	
	Rated voltage (V)	230	
	Rated output power (kW)	8.0	9.0
	Power factor	1	
	AC output quality	ISO8528 G2	
	Charging voltage (DC) (V)	12	
	Charging current (DC) (A)	8.3	
	Overload protection (DC)	Fuse-free protection	
Motor	Motor	R500DT-Vi	
	Engine type	Single-cylinder, four-stroke (OHV)	
	Displacement (cc)	500	
	Fuel type	PROPANE, PETROL	
	Fuel tank capacity (l)	29.8	
	Oil capacity (l)	1.2	
	Ignition model number	F7RTC	
	Starting method	Electric and manual start	
Generator set	Length × width × height (mm)	848 × 645 × 710	
	Net weight (kg)	105	

## HOW TO CONNECT THE BATTERY

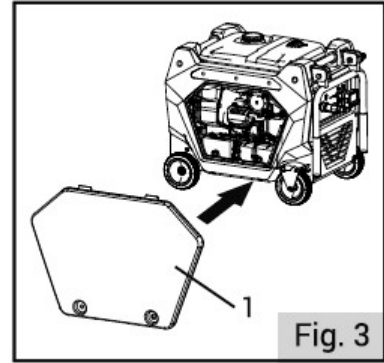
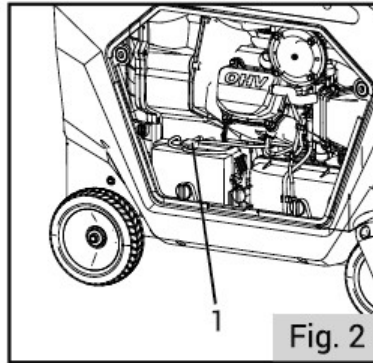
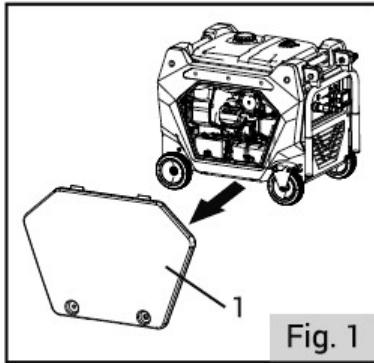

### CONNECTING THE BATTERY:

1. Remove the cover (Fig. 1-1).
2. Connect the black cable to the negative terminal of the battery (Fig. 2-1).

**NOTE:** The positive terminal of the alternator is already connected. Check that the positive terminal connection is secure.

1. Refit the cover (Fig. 3-1).

**IMPORTANT:** If you are not going to use the generator for a long period of time, we recommend disconnecting the negative cable from the battery. This will prevent the battery from discharging. After disconnecting the negative cable, cover the exposed end of the cable with insulation, such as electrical tape. Alternatively, you can use a trickle charger (not supplied) to maintain the battery charge.

## **FUEL SELECTION**

a. Petrol: Set the fuel source switch to GAS.

b. LPG:

1. Connect the LPG hose to the LPG tank;
2. Slide the quick-connect coupling sleeve back, insert the LPG inlet, loosen the quick-connect coupling sleeve and ensure that the sleeve fits snugly around the LPG inlet;
3. Set the fuel source switch to PROPANE.