



MAMMOTION

EN

USER MANUAL

LUBA mini AWD LiDAR

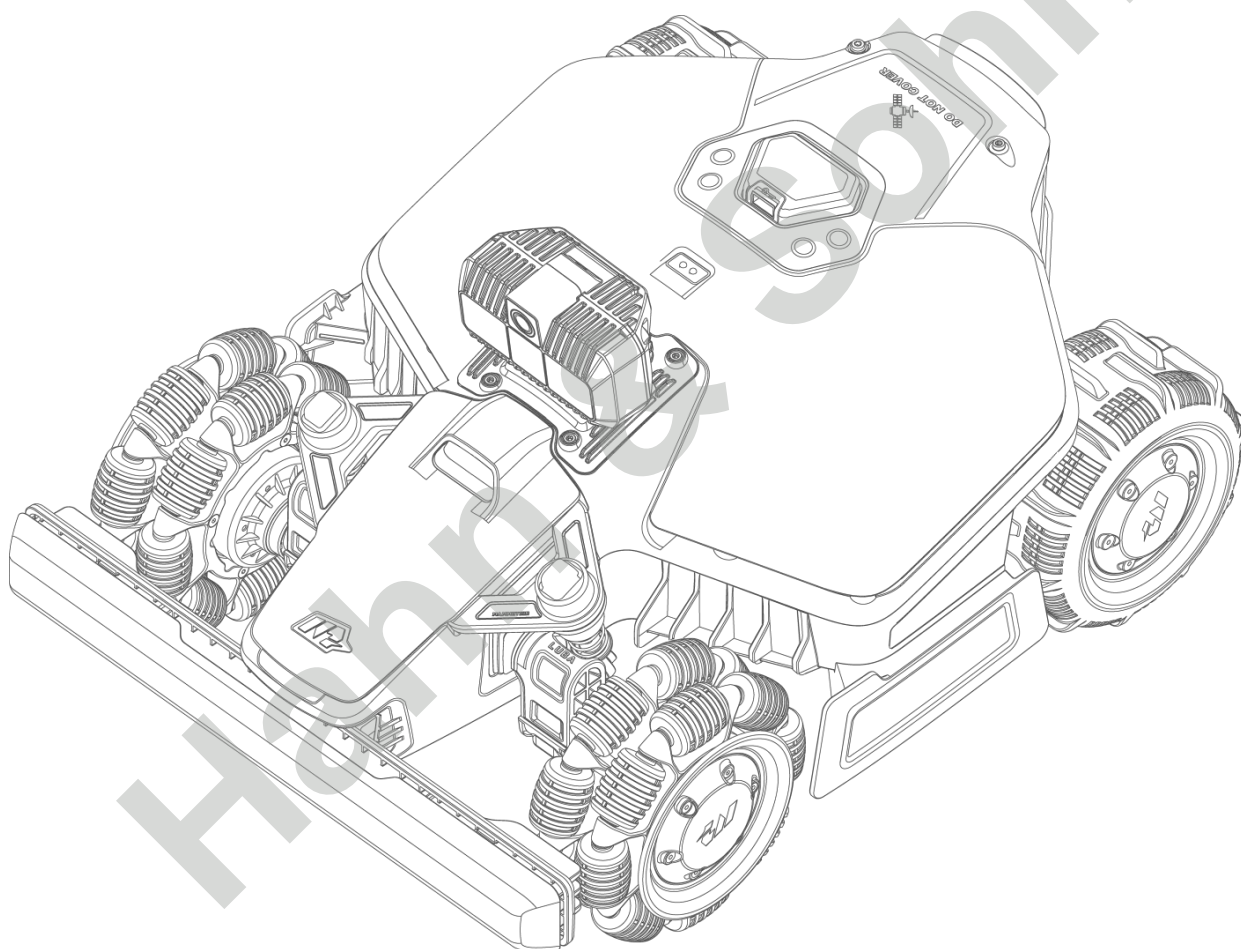

Original instructions **Version 1.0**

05/2025

Thank you for choosing a Mammotion mower for your lawn care. This user manual will help you learn how to operate the Mammotion robot, an all-wheel-drive, boundary-wire-free lawn mower, to cut the grass and maintain your lawn.

This manual is protected by Mammotion's copyright. No entity or individual may copy, modify, reproduce, transcribe or transmit this manual in any way or for any reason without the company's written permission. This manual is subject to change at any time without notice.

Unless expressly agreed otherwise, this manual serves solely as a user guide, and all statements and information contained herein do not constitute any form of warranty.

Revision history

Date	Version	Description
05/2025	V1.0	First version



BLAKAR trading s.r.o. declares that the specified product LUBA is in conformity with and complies with Directive 2014/53/EU. The full version of the declaration of conformity is available at www.blakar.cz/prohlaseni-o-shode/



All electrical and electronic products must be disposed of separately from household waste via designated collection points. The environmentally sound disposal of this equipment is ensured through the Asekol collective scheme (www.asekol.cz). Used batteries or accumulators do not belong in unsorted waste; you can hand them in free of charge at many locations designated as 'collection points' by Asekol (www.asekol.cz).



The ZELENÝ BOD mark is a registered trademark. ZELENÝ BOD indicates that a financial contribution has been paid for this packaging to an organisation responsible for the collection and recycling of packaging waste in accordance with EC Directive 94/62 (www.ekokom.cz).

CONTENTS

1	Safety instructions	- 1 -
	1.1 General safety instructions	- 1 -
	1.2 Safety instructions for installation	- 2 -
	1.3 Safety instructions for operation	- 3 -
	1.4 Safety instructions for maintenance	- 3 -
	1.5 Battery safety	- 4 -
	1.6 Residual risks.....	- 4 -
	1.7 Intended use	- 4 -
	1.8 Disposal	- 4 -
2	Introduction	- 5 -
	2.1 How the LiDAR module works.....	- 5 -
	2.2 Package contents	- 6 -
	2.3 Symbols on the product	- 7 -
	2.4 Product description	- 9 -
3	Installation	- 14 -
	3.1 Preparation.....	- 14 -
3.2	Selecting the location of the charging station	- 14 -
	3.3 Installation	- 16 -
4	Operation	- 18 -
	4.1 Preparation.....	- 18 -
4.2	Downloading the Mammotion app	- 18 -
	4.3 Adding your mower	- 19 -
	4.4 Activating the SIM card	- 20 -
	4.5 Updating the firmware	- 20 -
	4.6 Creating a map	- 21 -
4.7	Mowing.....	-29-
	4.8 Task schedule.....	- 35 -
	4.9 Manual mowing	- 36 -

4.10	Activating FPV mode	- 37 -
4.11	Status display	- 38 -
4.12	Settings	- 39 -
4.13	Service page	- 42 -
4.14	Profile	- 43 -
5	Maintenance	-49-
5.1	Cleaning	- 49 -
5.2	Maintenance of cutting blades and engine	- 50 -
5.3	Battery maintenance	- 52 -
5.4	Storage in winter	- 54 -
6	Product specifications	- 56 -
6.1	Technical data.....	- 56 -
6.2	Error codes	- 57 -
7	Simplified EU Declaration of Conformity	- 58 -
8	Warranty certificate	- 59 -

Hahn & Sohn

1 Safety instructions

1.1 General safety instructions

- Before using the robot, please read the operating instructions carefully and ensure you understand them.
- We recommend that the robot is used only by persons who are legally considered adults in their country of residence.
- Use only genuine accessories recommended by Mammotion for use with the robot. Any other use or non-genuine accessories is incorrect.
- Never allow the robot to be used by children, persons with reduced physical, sensory or mental capabilities, or those without the necessary experience and knowledge, or people who are not familiar with

Follow these instructions. The age of the operator may be restricted by local regulations.

- When the robot is in operation, do not allow children to be near it or to play with it.
- Do not use the robot in areas where there are people who are unaware of its presence.
- When controlling the robot manually using the Mammotion app, do not run. Always walk, watch your step on slopes, and constantly try to maintain your balance. You are now fully responsible for the robot.
- Do not touch any moving parts of the machine, such as the cutting disc or wheels, until it has come to a complete stop.
- Do not use the robot if there are people, particularly children, or animals in the working area.
- If you are operating the robot in public areas, place warning signs around the working area with the following text: "Warning! Automatic lawn mower! Keep away from the robot! Supervise children!"
- Wear sturdy footwear and long trousers when operating the robot.
- Never set routes or pathways across public roads to prevent damage to the robot and accidents involving vehicles and people.

- Seek medical attention in the event of injury or an accident.
- Before clearing blockages, carrying out maintenance or inspecting the robot, **switch it off** and remove the key. If the robot vibrates unusually, check that it is not damaged. Do not use the robot if any part is faulty.
- Do not connect or touch a damaged cable until it has been unplugged from the socket. If the cable becomes damaged during use, unplug the plug from the socket. A worn or damaged cable increases the risk of electric shock and must be replaced with a new one.
- Only use the charging station included in the pack to charge the robot. Incorrect use may result in electric shock, overheating or leakage of corrosive liquid from the battery. In the event of electrolyte leakage, rinse with water or a neutralising agent; and if the corrosive liquid comes into contact with your eyes, seek medical attention.
- Use only genuine batteries recommended by Mamotion. The safety of the robot cannot be guaranteed when using non-genuine batteries. Do not use non-rechargeable batteries.
- To prevent damage to the cables, which could result in contact with live parts, keep extension cables out of the reach of moving parts of the product.
- The images used in this document are for illustrative purposes only. Please refer to the specific products.
- Keep the charging contacts on both the product and the charging base clean and dry. Prevent snails and slugs from accessing the charging contacts on the product and the charging base, as they may cause irreparable damage them.

1.2 Safety instructions for installation

- Do not install the charging base in places where people might trip over it.
- Do not install the charging station in areas where there is a risk of standing water.
- Do not install the charging station under concrete or metal canopies.
- Do not install the charging station, including all accessories, within 60 cm of any flammable material. A fault or overheating of the charging station and power supply may pose a fire hazard.
- Do not place cable runs where sprinklers are installed.
- Do not use the product or the charging base in a strong magnetic field, in a highly flammable environment, or in an environment containing volatile substances or gases.

1.3 Safety instructions for use

- Keep your hands and feet away from the rotating blades. When the robot is switched on, do not place your hands or feet near the robot or underneath it.
- Do not lift or move the robot whilst it is switched on.
- If there are people, particularly children or animals, in the working area, stop the robot.
- Make sure there are no objects such as stones, branches, tools or toys on the lawn. Otherwise, the blades could be damaged if they come into contact with an object.
- Do not place objects on the robot or the charging station, and do not stand or sit on them.
- If the **STOP** button does not work, do not use the robot.
- Prevent the robot from colliding with people or animals. If a person or animal steps into the robot's path, stop the robot immediately.
- When the robot is not in use, always set it to the **OFF** position.
- Do not use the robot at the same time as pop-up sprinklers. Use the scheduling function to ensure that the robot and the pop-up sprinklers are not in operation at the same time.
- Do not set routes through areas where pop-up sprinklers are installed.
- Do not use the robot if there is standing water in the working area, such as during heavy rain or when puddles form.

1.4 Safety instructions for maintenance

- Switch off the robot before carrying out maintenance. Remove the safety key from the robot.
- Before cleaning or carrying out maintenance on the charging station, unplug the charging station.
- Do not use a high-pressure cleaner or solvents to clean the robot.
- After washing, ensure that the robot is placed on the floor in its normal orientation, not upside down.
- To clean the chassis, do not turn the robot upside down. If you turn it over for cleaning purposes, remember to return it to the correct orientation afterwards. This precaution is necessary to prevent water from entering the motor and potentially impairing normal operation.
- Do not touch the charging contacts on the product or the charging base with your bare hands.
- Do not spray water or any liquid cleaning products onto the underside of the robot.

1.5 Battery safety

If lithium-ion batteries are disassembled, short-circuited, exposed to water, fire or high temperatures, they may explode or cause a fire. Handle them with care, do not disassemble or open them, and prevent any electrical or mechanical damage. Store them out of direct sunlight.

- Use only the battery charger and power supply provided by the manufacturer. Using an unsuitable charger and power supply may result in electric shock and/or overheating.
- DO NOT ATTEMPT TO REPAIR OR MODIFY THE BATTERIES! Attempts to repair them may result in explosion or electric shock, resulting in serious injury. In the event of a leak, the leaked electrolyte is corrosive and toxic.
- This appliance contains batteries that may only be replaced by qualified personnel.

1.6 Residual risks

- To prevent injury, wear protective gloves when replacing the blades.
- If you have a garden pool, ensure that the product cuts the grass at a sufficient distance from the edge of the pool (min. 50 cm). The product has an IPX6 water resistance rating, but is not completely waterproof.
- The IPX6 water resistance rating applies to the product in its operating position.
- The user is responsible for any accidents or hazards that may occur to other persons on their property.
- The product may only be repaired or modified by an authorised service centre or by a qualified person who has been trained at an authorised service centre.
- Operating and storage temperature: 0°C - 45°C. Operating temperature for charging: 4°C - 40°C

1.7 Intended use

Mammotion robots are designed for domestic lawn care and are not intended for commercial use.

1.8 Disposal

Disposal of this product complies with the Waste Electrical and Electronic Equipment (WEEE) Directive. Do not dispose of the product with ordinary household waste. Instead, take it to an authorised recycling centre or collection point to ensure the safe and environmentally sound handling and disposal of electronic components.

2 Introduction

2.1 How the LiDAR module works

The robot's positioning system integrates advanced LiDAR (Light Detection and Ranging) technology with an AI-powered tracking camera, enhancing its ability to collect highly accurate spatial data in real time.

2.1.1 LiDAR module

- The LiDAR module emits laser pulses and measures the time taken for them to return after striking obstacles.
- The robot creates a map of its surroundings in real time and estimates its position within them.
- LiDAR detects objects such as trees, fences or garden furniture, enabling the robot to navigate safely.

2.1.2 Camera with AI tracking

- Image processing using artificial intelligence helps to detect and recognise objects such as pets, toys or specific areas of grass.
- A camera with AI tracking helps the robot identify grassy areas for better navigation.

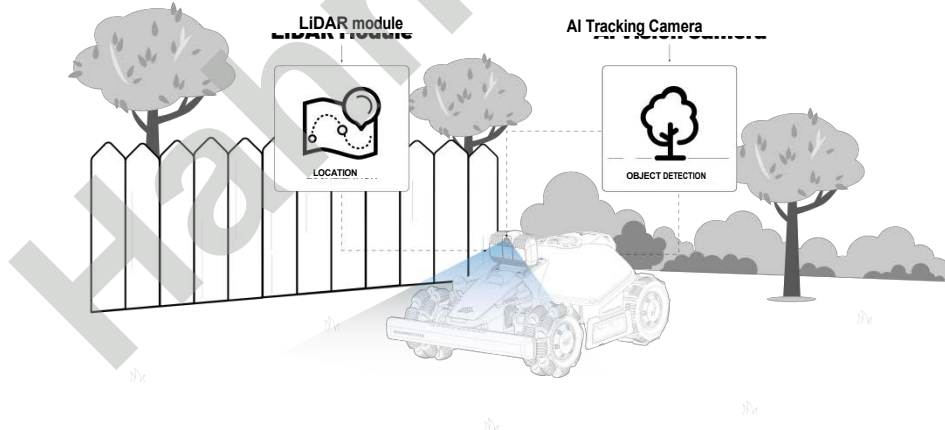

2.2 Package contents

Please ensure that all the accessories listed below are included in the package. If any parts are missing or damaged, please contact your dealer or our after-sales support immediately. Mammotion recommends keeping the packaging for future transport or storage.

2.2.1 LUBA mini AWD installation kit

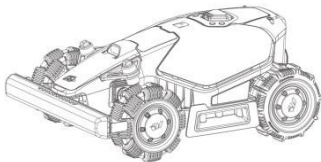

1× LUBA mini AWD LiDAR



1× LiDAR module



1× safety key (for replacement use)

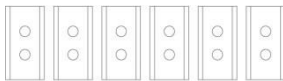

6× blade (for replacement)



6× screw (for spare parts)

2.2.2 Charging station installation kit

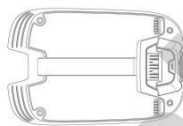

1× charging station base



Rain cover



1× charging station power supply

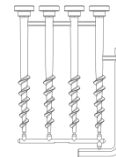

1 set of pegs

2.2.3 Tool set

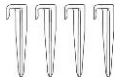

4× cable pegs



1× brush

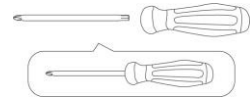







1× screwdriver (Phillips bit + T20 hex bit)

2.3 Symbols on the product

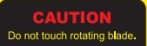
You will find the following symbols on the product. Please study them carefully.

Symbol	Description
	Warning.
	Read the user manual before using the product.
	The product complies with applicable EU directives.
Made in China	The product is manufactured in China.
	This product must not be disposed of as ordinary household waste. Ensure that the product is recycled in accordance with local legal requirements.
	Use the TS-A081-2703002 detachable power supply unit.
	This item can be recycled.
	Keep the product packaging in a dry place.
	The product packaging should not be covered.
	Do not tip over.
	The product is fragile.

	<p>Do not step on the product packaging.</p>
	<p>Class III appliance.</p>
	<p>WARNING – do not touch the rotating disc.</p>
	<p>WARNING – read the user manual before using the product.</p>
	<p>WARNING – keep a safe distance from the machine during operation.</p>
	<p>WARNING – remove the safety device before working on the machine or lifting it.</p>
	<p>WARNING – Do not ride on the machine. Never place your hands or feet near or under the product.</p>

2.4 Product description

2.4.1 LUBA mini AWD LiDAR

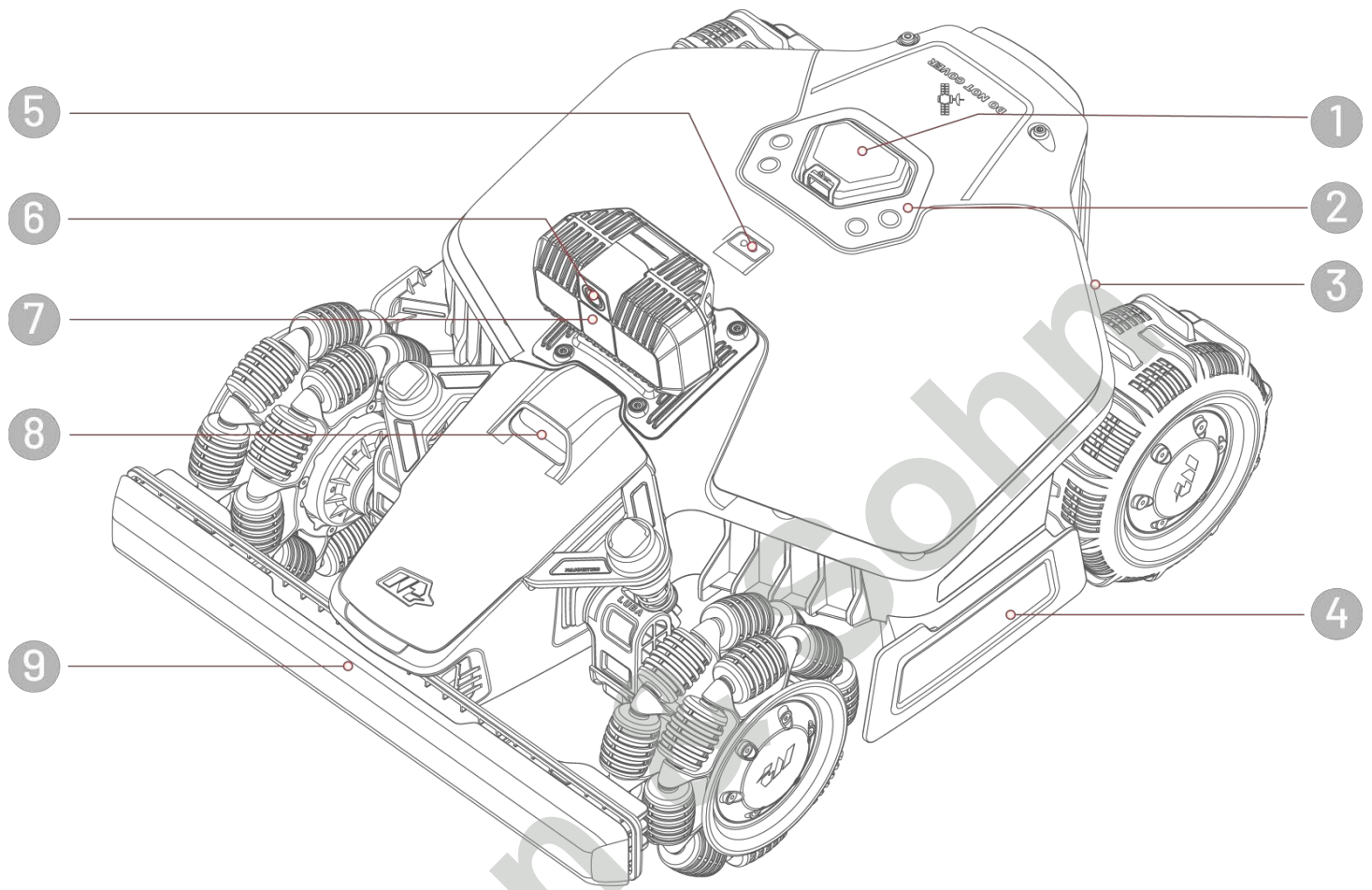

1. Emergency stop button

3. Side LED indicator

5. Rain sensor

7. LiDAR module

9. Bumper

2. Control panel

4. Handle

6. Camera with AI tracking

8. Additional lighting

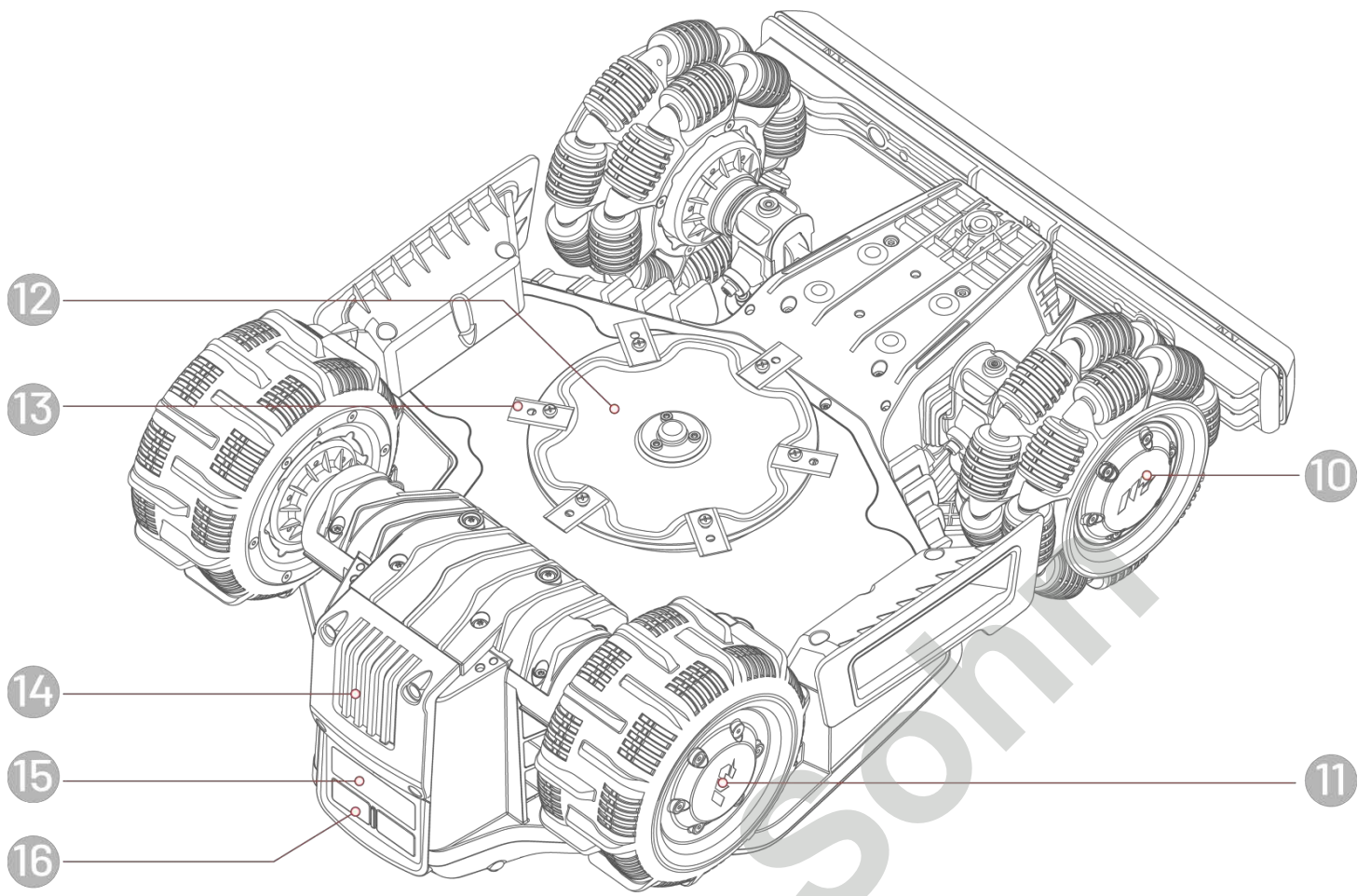

10. Omnidirectional wheel

12. Cutting disc

14. Replaceable battery

16. Charging contact







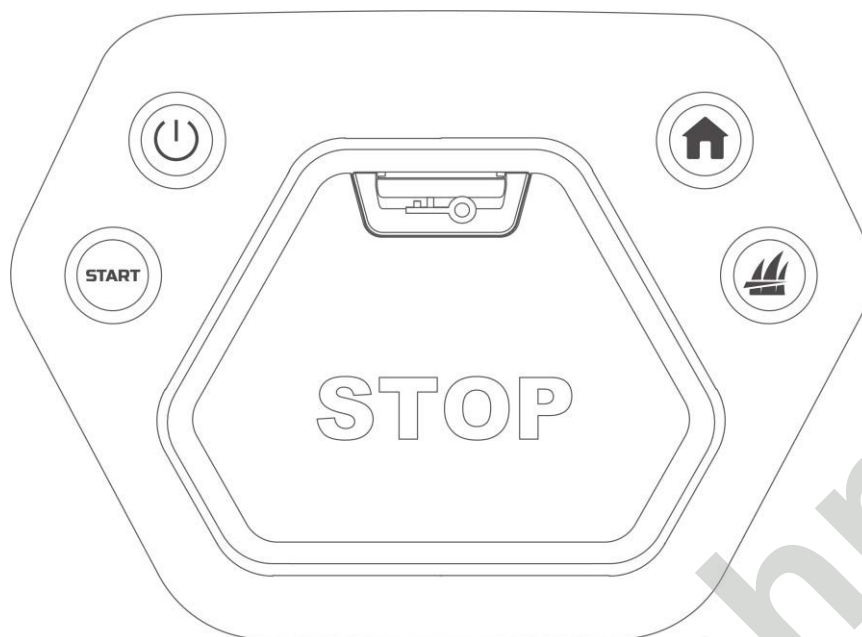

11. Rear wheel

13. Cutting blade

15. Infrared receiver

Control panel



Button/icon	Name	Description
	Home button (to charging station)	<ul style="list-style-type: none"> ● Press the '' button, then press the 'START' button to return to the charging station. ● Press the '' button, then press the 'START' button to resume work/unlock the robot. ● Press the '' button twice to fully lower the mower deck for cleaning.
	Mowing button	
START	Start button	
	Power Switch	Press and hold the robot's  button to switch it on/off.
	Emergency button	If unexpected problems occur, press the button to stop the robot immediately.

2.4.2 Charging station

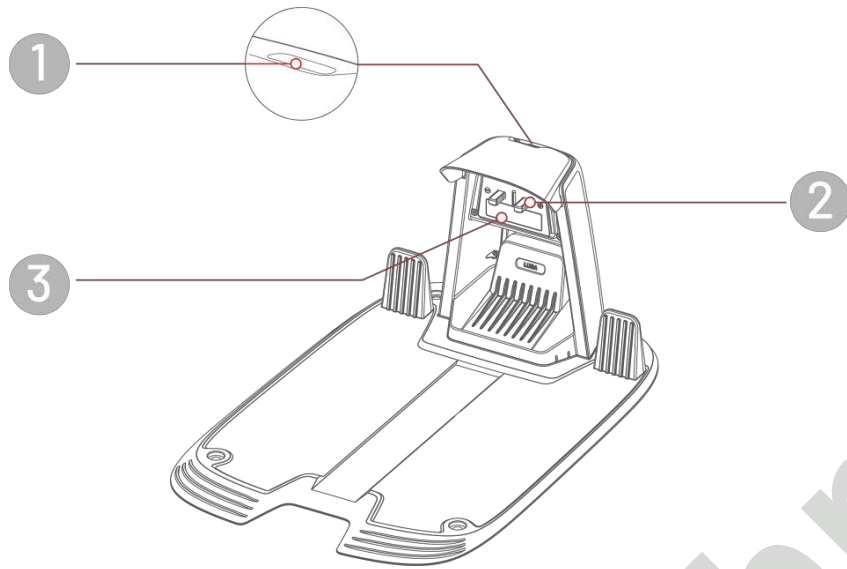

1. Charging station LED indicator

2. Charging contact

3. Infrared transmitter

Hahn & Sohn

2.4.3 LED indicator codes

Robot

Indicator	Status	Description
Side LED indicator	Constant red	The robot is working properly.
	Flashing red	<ul style="list-style-type: none">● OTA upgrade in progress● The robot is charging
	Slowly flashing red	<ul style="list-style-type: none">● The emergency stop button has been activated● Low battery● The safety key is not properly installed● Robot is stuck● The robot has been lifted/tilted/overturned
	Rapidly flashing red	<ul style="list-style-type: none">● A robot system fault has occurred● Robot system upgrade failed
	Not lit	<ul style="list-style-type: none">● The robot is switched off● Robot is in sleep mode● The side LED indicator is turned off in the app● The robot is in manual mode but is currently inactive

Charging station

Colour	Description
Flashing green	The robot is parked in the charging base.
Steady Green	The robot is not in the charging station.
Steady red	Charging station fault
Not lit	No power

3 Installation

3.1 Preparation

- Read and understand the safety instructions before installation.
- Use genuine parts and installation materials.
- Sketch out your lawn and mark any obstacles. This will make it easier to decide where to place the charging station and set up the virtual boundaries.
- Before using the robot, mow the lawn to a height of max. 10 cm.

3.2 Choosing the location for the charging station

- Place the charging station on a flat surface.
- Do not install the charging station on the corner of an L-shaped building or in a narrow passage between two structures.
- The charging area (1 × 1 m in front of the charging station) should be free of obstacles or other objects.
- The base plate of the charging station must not be bent or tilted.

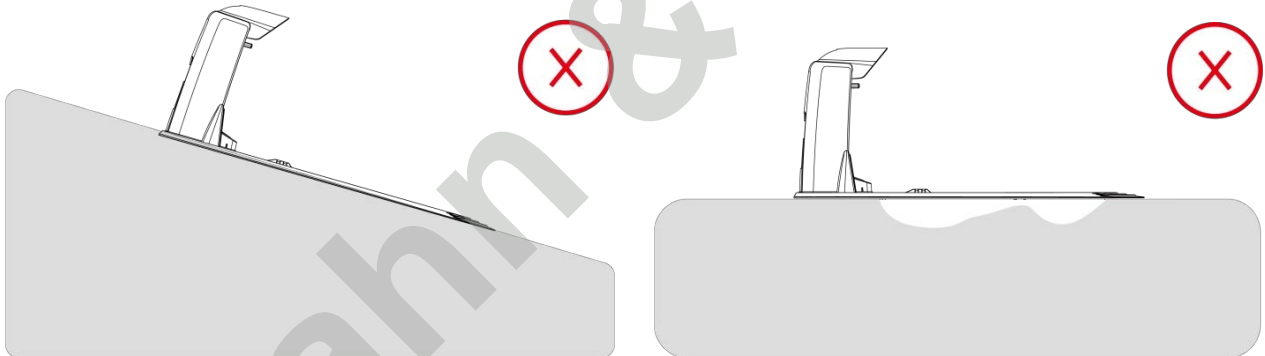

- Position the charging station so that it faces the lawn.

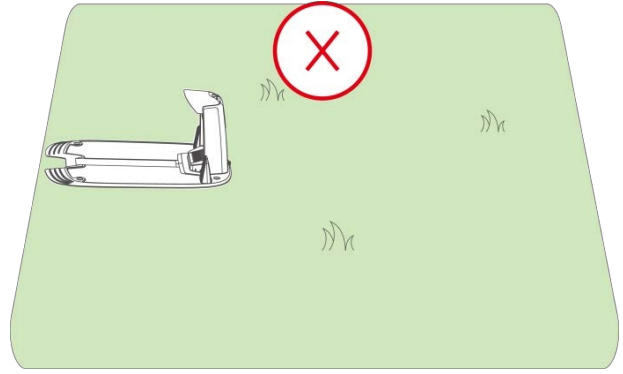
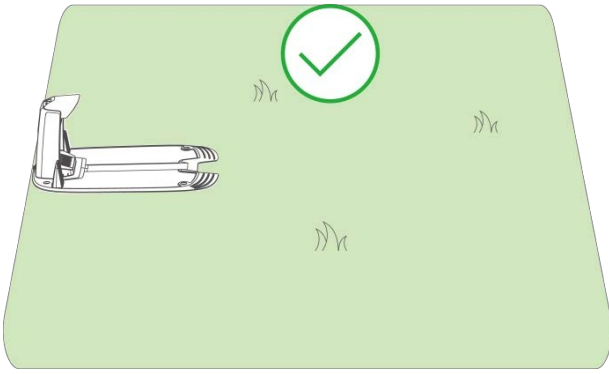

- If the charging station is located away from the lawn, create a connecting path to link it to the lawn.



NOTE

If the charging station is installed on a concrete surface, secure it using expansion bolts.

3.3 Installation

3.3.1 Installing the LiDAR module

1. Remove the cover.
2. Connect the LiDAR module connectors so that they match the corresponding three connectors in both colour and shape.
3. Arrange the cables neatly, then secure the LiDAR module in place and tighten the screws using a hex key.
4. Peel off the sticker.

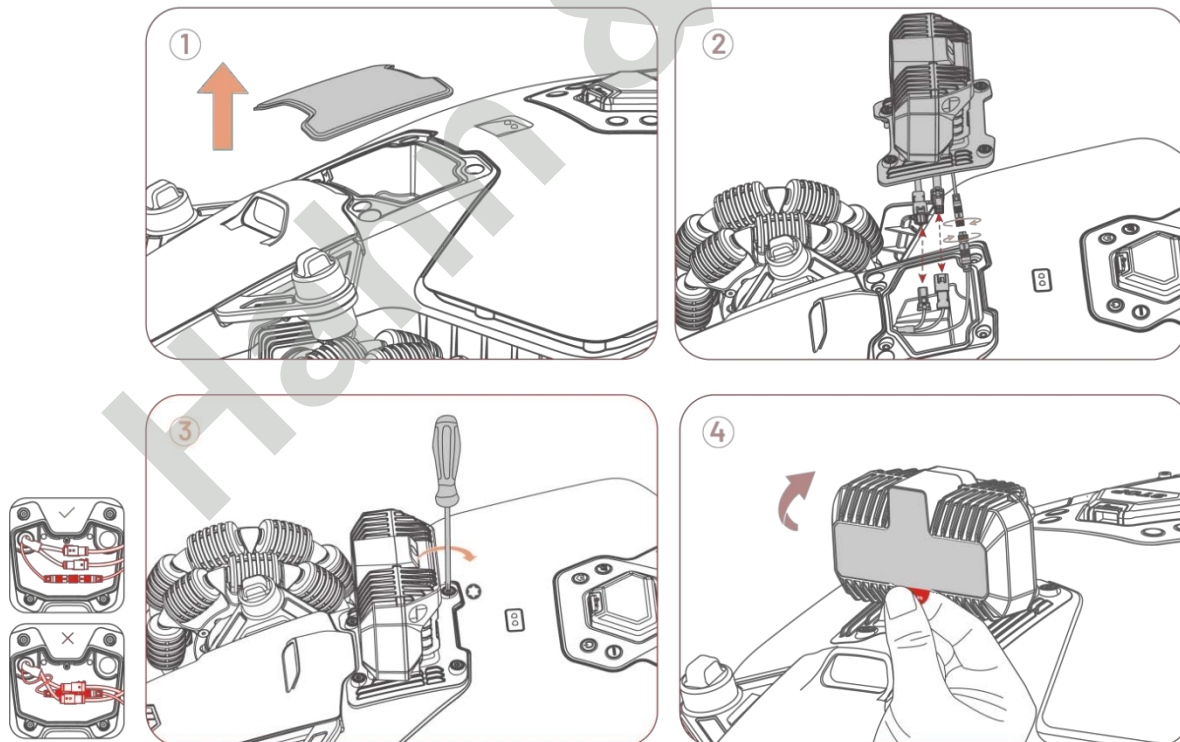
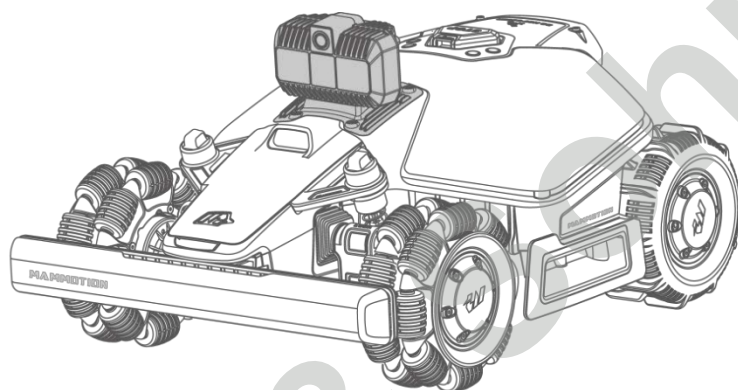

3.3.2 Installing the charging station

1. Assemble the charging station.

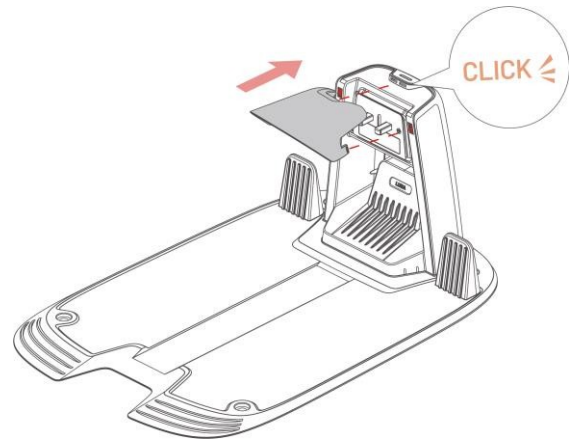

2. Choose an open space for installing the charging station and ensure that the area in front of it is free of obstacles.

3. Secure the charging station in place using 4 pegs and an Allen key.

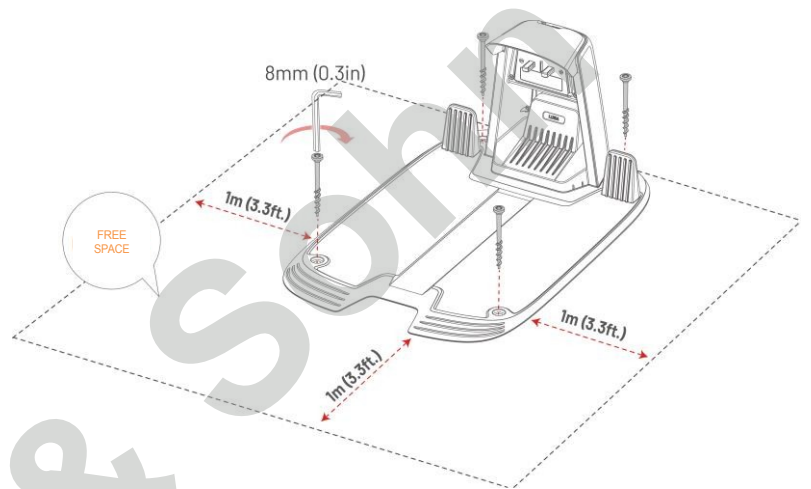

4. The cable (the longer one) of the charging station to the charging station's power supply station.

5. Plug the charging station's power supply into a socket.

6. Do not switch on the robot; instead, place it manually on the charging station and start charging. The robot will activate itself.

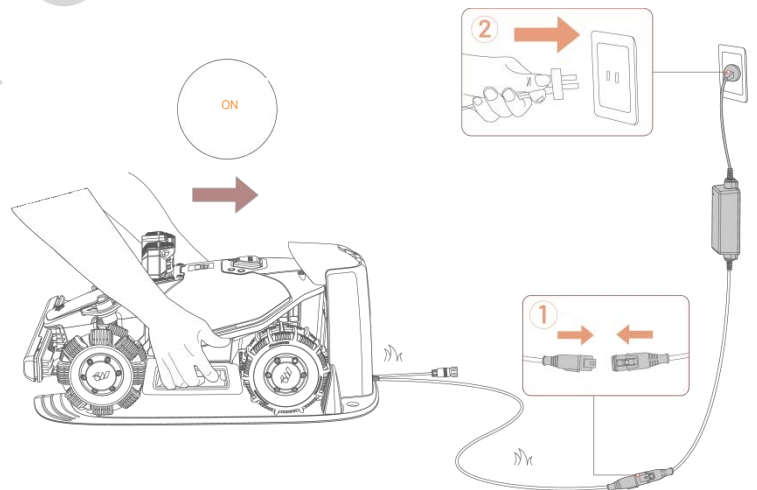

IMPORTANT

TO ACTIVATE THE ROBOT, MANUALLY PLACE IT ON THE CHARGING STATION.

4 Operation



NOTE

The images are for illustrative purposes only.

4.1 Preparation

- Read and understand the safety instructions before use.
- The charging station is correctly installed.
- Make sure the robot is already connected to the charging station.
- Make sure you have a stable network connection and keep your phone switched on with Bluetooth enabled.

4.2 Download the Mammotion app

The robot is designed to work with the Mammotion app. Please download the free Mammotion app first. You can scan the QR code below to get it for free from the Android or Apple app stores, or search for the Mammotion app in these stores.



Once you have installed the app, please register and log in. Whilst using the app, you may be asked to grant access to Bluetooth, your location and your local network, where necessary. To ensure the best possible experience, we recommend allowing the above access. For more information, please see our Privacy Policy. Go to the Mammotion app > **Profile** > **About Mammotion** > **Privacy Policy**. If you wish to log in using a third-party account, proceed to the login page by tapping

 or  . The Mammotion app now supports sign-in via Google and Apple accounts.

4.3 Adding your mower



NOTE

- Make sure the distance between your phone and the robot is less than 3 m.
- If you are using 4G mobile data, you can skip the Wi-Fi setup. For optimal performance, it is also recommended to connect to a Wi-Fi network.

4.3.1 Adding a device

1. Tap **+** to add your robot.
2. Select **Add**.
3. Follow the on-screen instructions to set up the device.
4. Follow the on-screen instructions to successfully connect the device and set up the network.
5. To activate the built-in SIM card, follow the on-screen instructions.

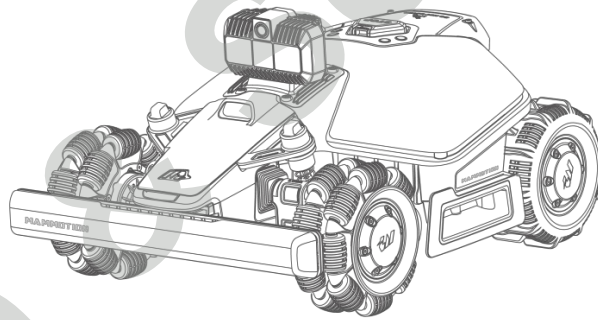
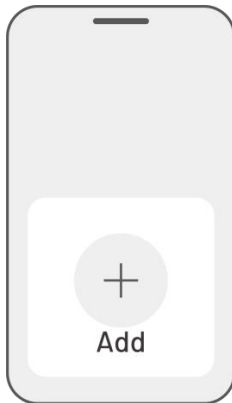

4.4 Activating the SIM card

If you did not activate the SIM card during the device pairing process, you can do so by tapping the status bar on the home screen:

1. On the home screen, tap the **status bar**.
2. Tap the **4G Status** button.
3. Tap **Activate** and wait for the activation to complete successfully.



4.5 Firmware update

For the best experience, make sure your robot is updated to the latest firmware version.

➤ How to update the firmware

1. Go to **Settings > Device Information > Robot Version** and update the firmware.
2. Make sure the robot is connected to a stable network.

During the update, avoid closing the app, performing other operations or switching off the robot.



4.6 Creating a map

4.6.1 Mapping the working area

Before mapping

Before mapping, it is important to bear in mind some key points.

- Remove debris, piles of leaves, toys, wires, stones and other obstacles from the lawn. Ensure there are no children or animals on the lawn.



- The performance of the LiDAR module may be impaired by heavy rain, fog or thick dust. Do not use the robot in extreme weather conditions.
- Remove all reflective surfaces (e.g. mirrors and glass) from the lawn, as they may interfere with the LiDAR module's signals.

Mapping your lawn

1. Make sure the robot is switched on and that Bluetooth is enabled on your phone. Your phone will automatically connect to the robot via Bluetooth.

2. Tap **Create Map** to begin.





3. You will be prompted to calibrate the charging station.

4. Make sure the robot is docked in the charging station.

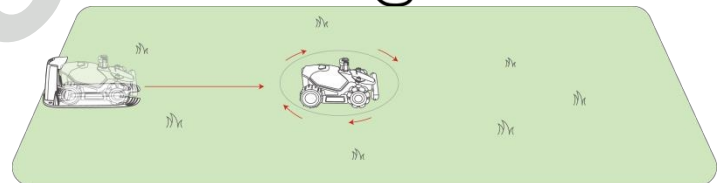
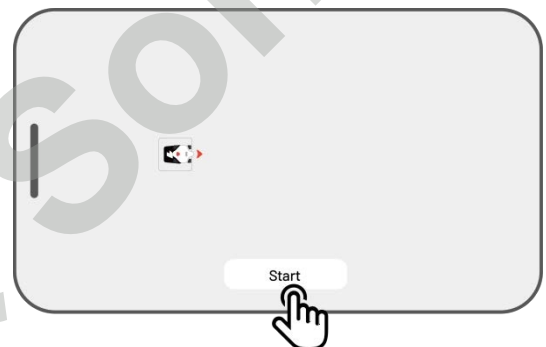
5. Start by tapping the **Start** button. The robot will automatically disconnect from the dock and rotate 360 degrees to achieve more accurate positioning.



6. Once processing is complete, guide the robot to the correct starting point of the perimeter and start mapping.

- You can control the robot's forward or backward movement controlled using the virtual joystick  up or down.
- Moving the virtual joystick  left or right will turn the robot left or right.

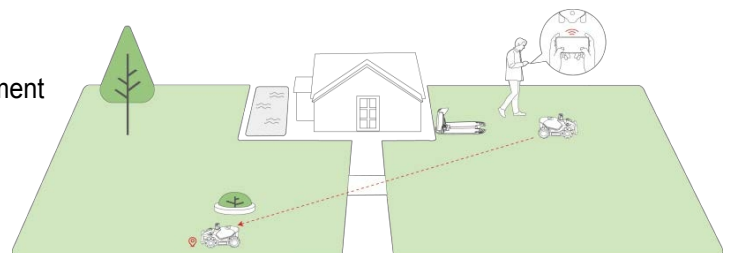

7. Continue by selecting **Manual Mapping** or **Automatic Mapping**.

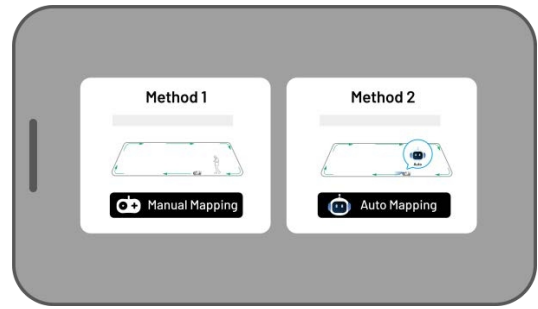

Manual mapping

1. Before starting, the robot performs a 360-degree scan to check whether the environment is suitable for LiDAR operation.
2. Tap **Start** to begin the scanning process.
3. Guide the robot around the perimeter. To maintain a stable Bluetooth connection, keep your phone within 1.5 metres of the robot.

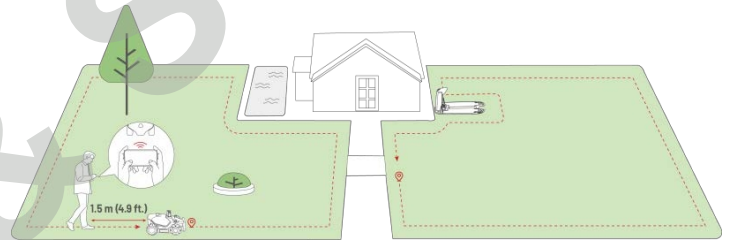
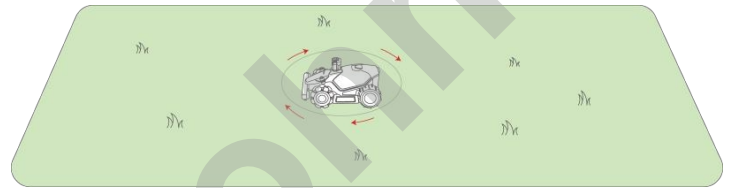

- a) If the perimeter/boundary encounters an obstacle, such as a wall, fence, hedge or uneven path, keep the robot at least 15 cm away from the perimeter/boundary whilst guiding it.

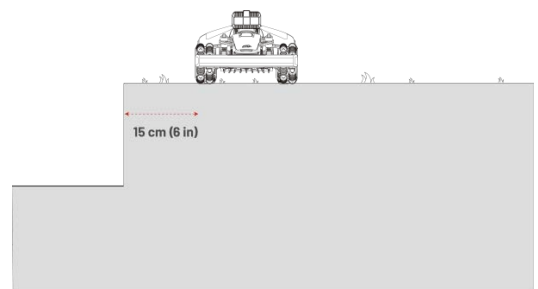

b) If the perimeter/boundary follows a straight and even path, we recommend guiding the robot along this path for more efficient mowing, e.g. the concrete edging of interlocking paving

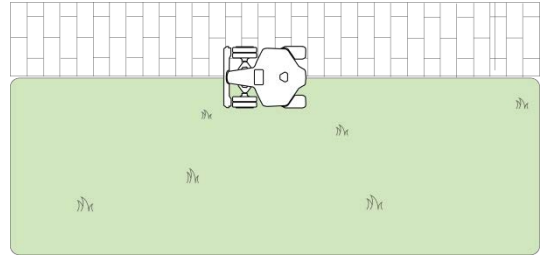

4. Tap **Cancel** to delete all unsaved data and, if necessary, remap during the mapping process.
5. Tap **Save** to guide the robot back to the starting point and complete the mapping.

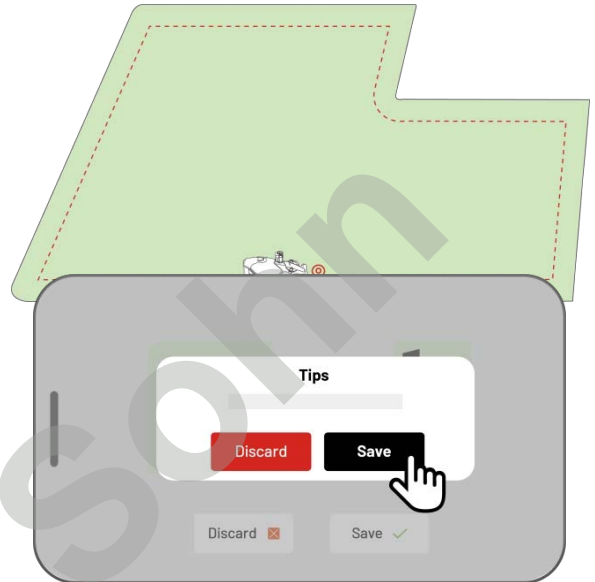

Automatic mapping

	<p>NOTE</p> <ul style="list-style-type: none">● Remove all obstacles before starting automatic mapping.● Keep your phone active and do not switch to other apps.● Keep an eye on the robot during the mapping process.● Ensure there is an uninterrupted Bluetooth connection between the robot and your phone.● Do not use Auto Mapping in areas with stairs, slopes, ponds, swimming pools or similar obstacles.
--	---

The Auto Mapping feature uses the robot's camera with AI tracking to detect the physical perimeter of the lawn. When the camera identifies an open perimeter, the Auto Mapping feature is activated, allowing the robot to map the perimeter of the lawn autonomously.

You can start this function by tapping the **Auto Mapping** option.

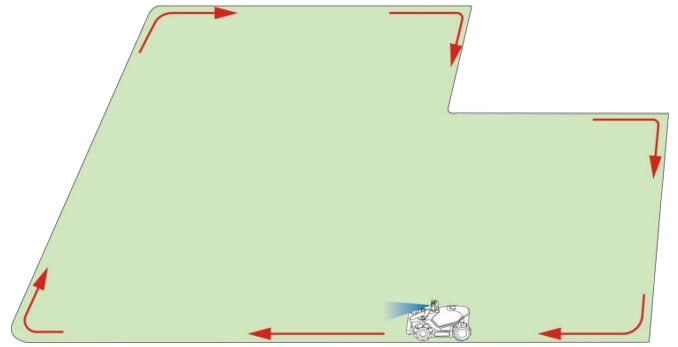

If the robot is not working properly, tap the **Stop** button and then control it manually to continue mapping.

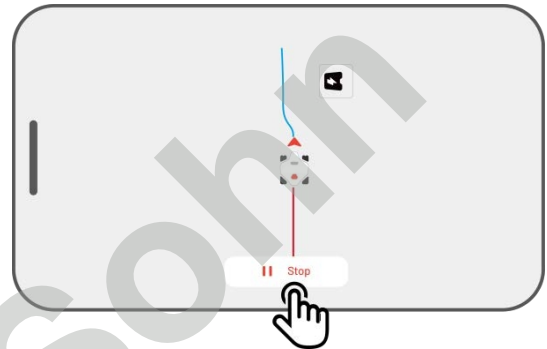

NOTE



- During mapping, the system estimates the area. Ensure that the area does not exceed the upper limit (see the [Technical Specifications](#) section for more information), otherwise mapping of the working area will fail.
- If a new area has already been created, first move the robot out of the existing work area or no-go zone.

4.6.2 Mapping of no-go zones

No-go zones are created for swimming pools, flower beds, trees, roots, ditches and other obstacles on the lawn. The robot will not mow within these designated areas.

1. On the Map page, tap **Create >**
No-go zone

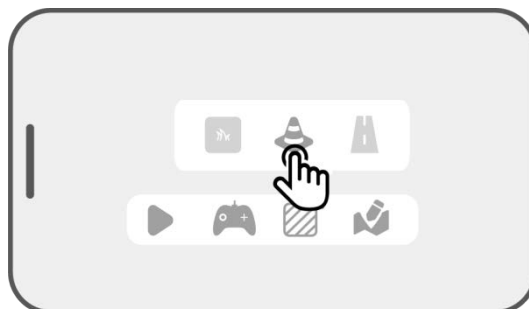

2. Guide the robot along the perimeter/boundary of the no-go zone, then tap '▶' to start mapping.

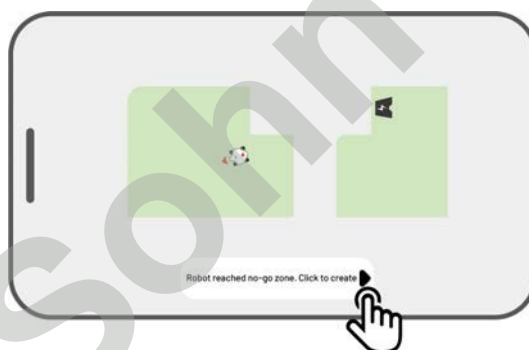

3. Guide the robot along the perimeter of the no-go zone and back to the starting point to complete the mapping of the no-go zone.

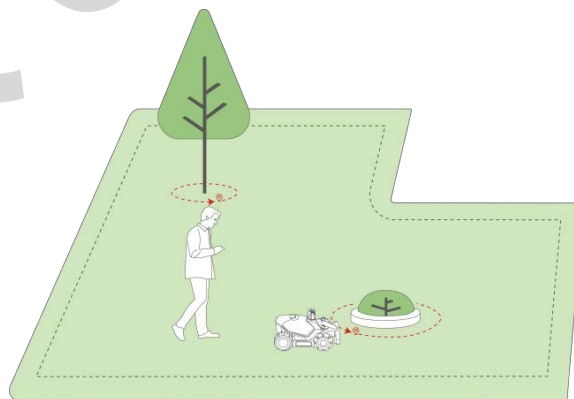

4. Tap **Save** to complete the setup.

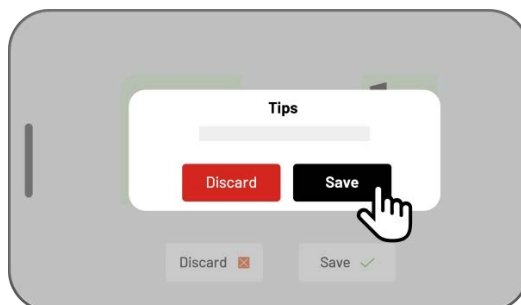

4.6.3 Mapping a connection route

A connection path is used to connect different areas or to connect areas and a charging station.

1. On the Map page, tap **Create > Connection path**

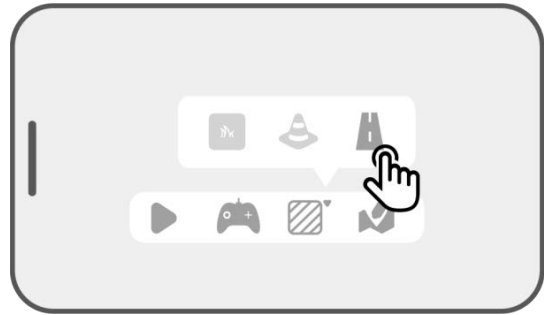

2. Guide the robot into the working area. Tap  to start mapping.

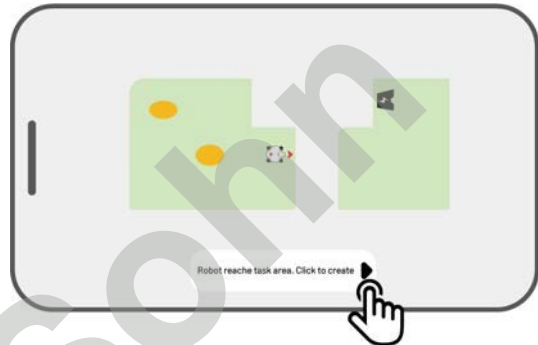

3. Manually guide the robot from the working area to another working area or to the charging station.

NOTE



- The connecting path should be wider than 1 m.
- The path should not have any significant unevenness.

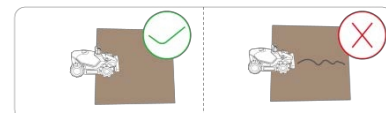
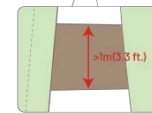
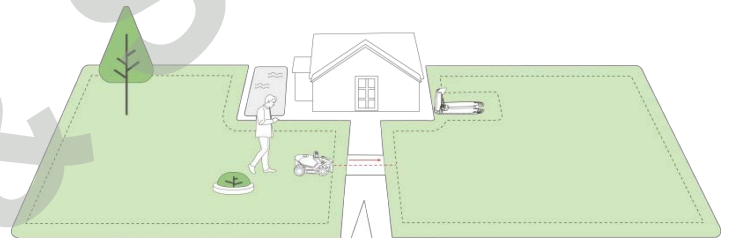

4. Tap **Save** to complete the settings.

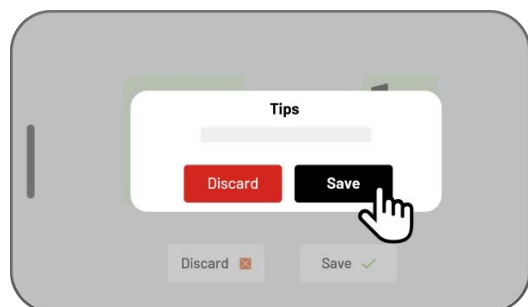

4.6.4 Editing the map

Renaming an area

The Mammotion app allows you to create multiple areas. You can rename an area for easy management.

1. Tap **Edit** > '●●●' to open the pop-up window.



2. Tap **Rename** to set the name of the area.

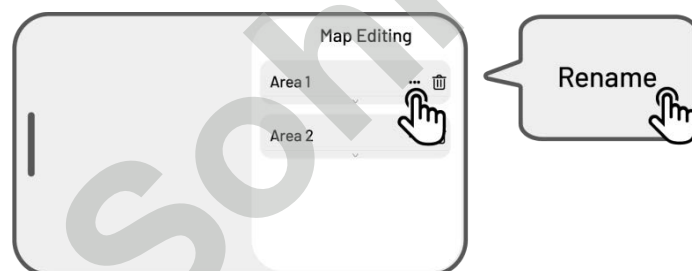

Deleting an area/restricted zone/connection path

To delete an area, restricted zone or link path, tap

Edit

>  . Deleting an area also deletes all items within it.



Multiple overlapping workspaces

If you have several lawns that overlap, the shared section will be assigned to the work area that was created first. No connecting path is required for two work areas with overlapping sections.

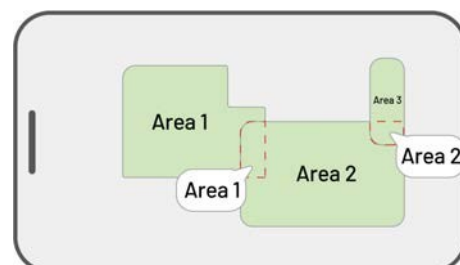

4.7 Mowing

4.7.1 Preparation

- If unexpected problems occur, press the **STOP** button and secure the robot. The STOP button has the highest priority of all commands.
- If the lift sensor is activated, the robot will stop. To unlock it, press the **Grass** button and then the **START** button.
- Mow the working area no more than once a day, as this can be harmful to your lawn.
- Before mowing, make sure the robot is at the charging station or in the working area. If not, manually move or guide the robot to the charging station or working area.

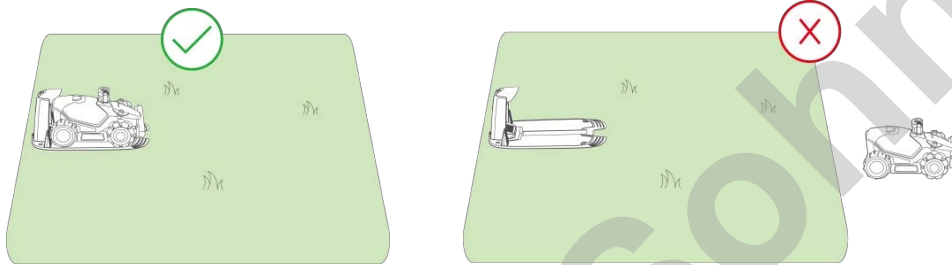

- Ensure that a connecting path is created between the working areas or between a working area and the charging station. Without this, the robot will not be able to return automatically to charge when the battery is low.

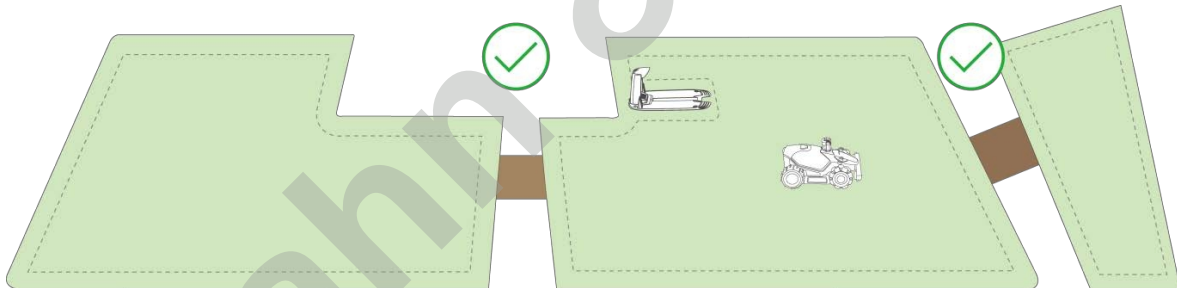

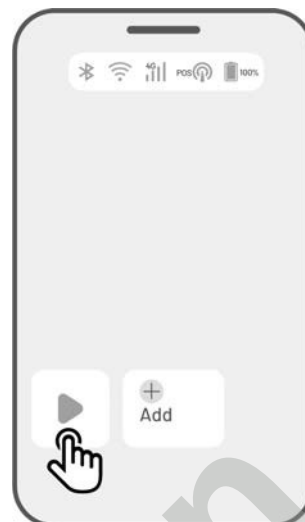

4.7.2 Starting mowing

If you do not wish to adjust the settings, simply go to the home page tap the option  and start mowing straight away.



If you prefer to adjust the settings before you start:

1. Tap the robot icon to go to the Maps page.
2. Tap the **Mow** button  to go to the task page.
3. Select the area you want to mow.
4. Tap on  to configure the settings.
5. Tap on the **Save** to apply the settings.
6. Tap the **Start** option to begin mowing or tap **Save** to create a task schedule.



Task settings

Frequency

Here you can set the operating frequency.

- ◇ **Now** – the robot will start working immediately after configuration.
- ◇ **Weekly** – the bot will repeat the task every week based on your preferences.
- ◇ **Frequency** – specify days off. For example, if you enter 3 days, the robot will work once every 4 days according to your settings.

Cutting height

You can set the cutting height using the app. **Task speed**

Here you can set the robot's working speed. **Mowing**

path angle (°)

● Optimal

Select the most efficient path recommended by the algorithm as the 0-degree direction.

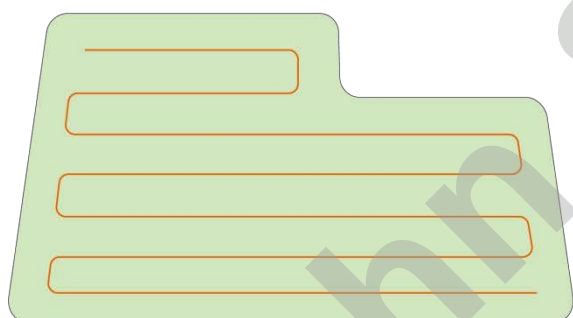

Before setting

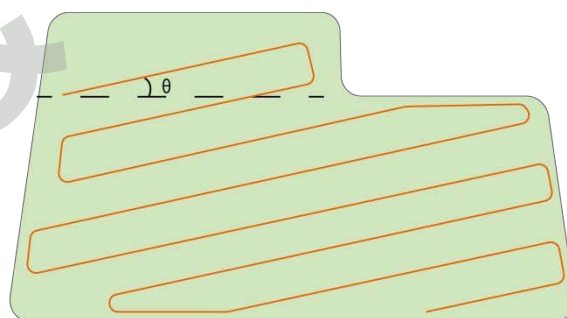

After setting

● Random

The mowing direction changes each time a new robot task begins.

● Customise

The angle adjustment range is 0 to 180°.

Mowing path mode

- **Perimeter only**

The robot mows the grass only along the perimeter.

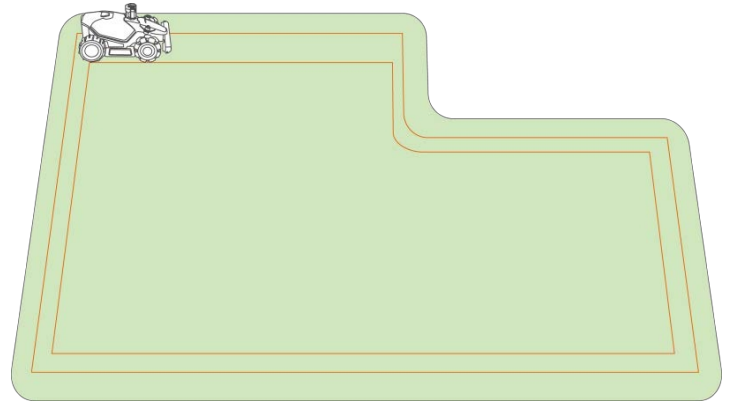

- **Simple grid (zigzag)**

The robot will mow in straight, simple rows.

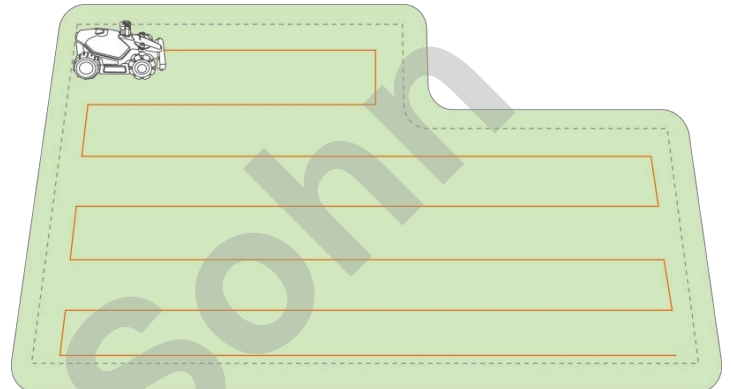

- **Checkerboard pattern**

The robot will work in straight rows both horizontally and vertically.

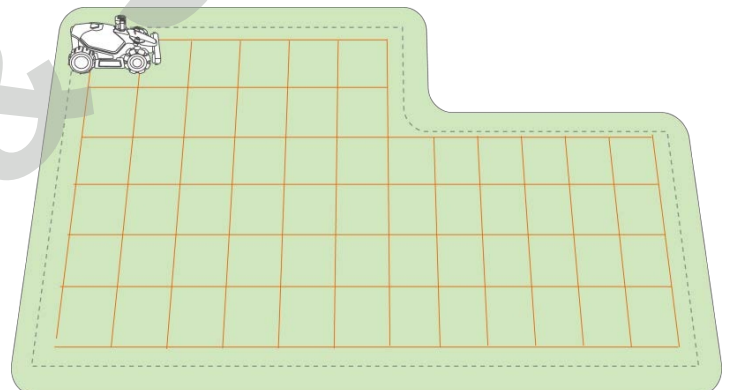

- **Adaptive simple grid**

The working area will be divided into zones for greater efficiency, and mowing takes place along the length of the area.

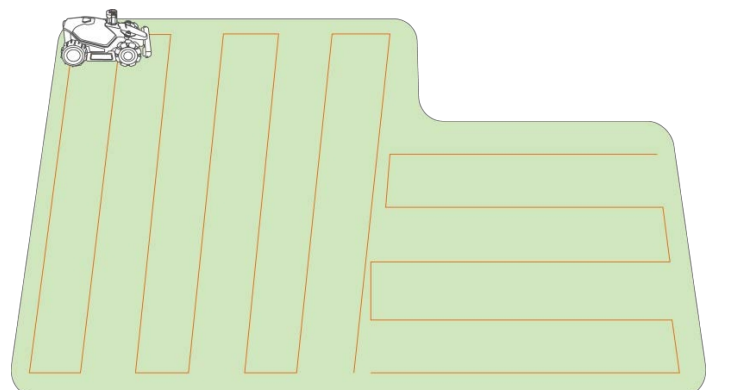

Perimeter mowing

If this option is enabled, the robot will clean along the perimeter. If this option is disabled, the robot will avoid cleaning along the perimeter.

Obstacle detection mode

❖ Off

The robot will attempt to reach all areas within the selected zone. If it encounters an obstacle, it will gently bump into it and then move around it; this ensures a cleaner path around walls and obstacles.

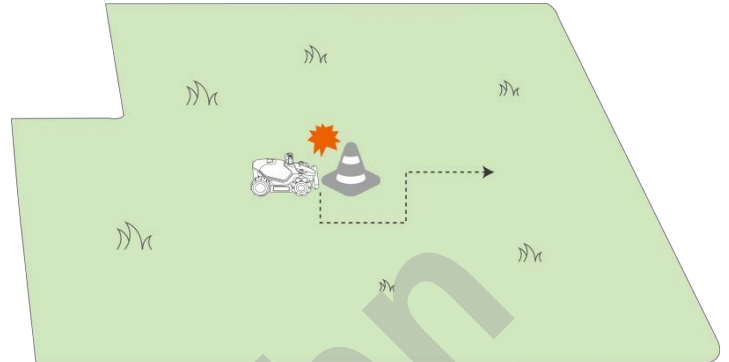

❖ Standard

The robot proactively avoids obstacles to prevent collisions, thereby reducing damage and improving efficiency.

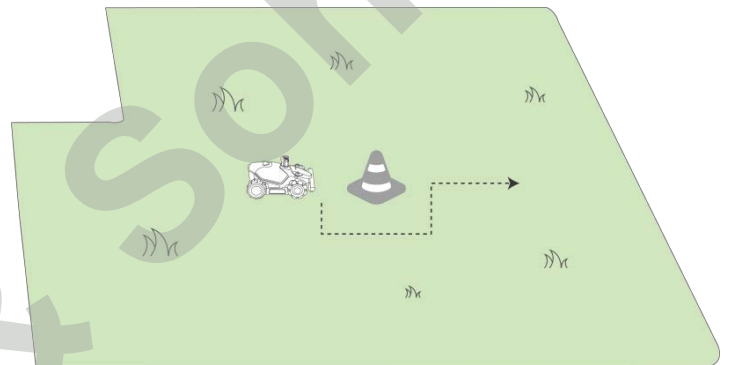

❖ Sensitive

The robot proactively avoids obstacles and areas without grass, thereby reducing the risk of it falling or leaving the lawn. However, it may miss some dry patches, and these could block the return route.

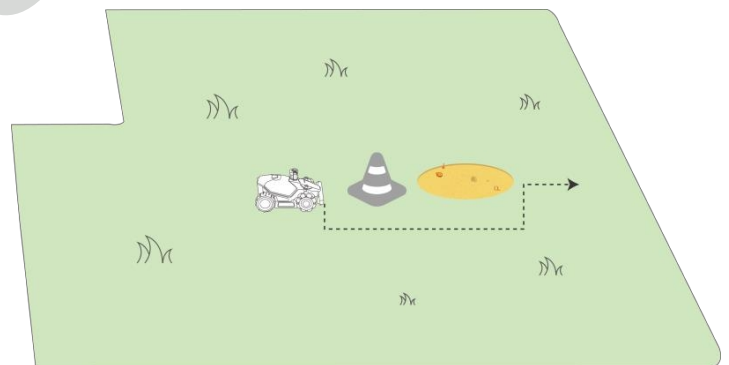

Mowing in prohibited zones (no-go zones)

When enabled, the robot will mow the no-go zone along the perimeter of two circles.

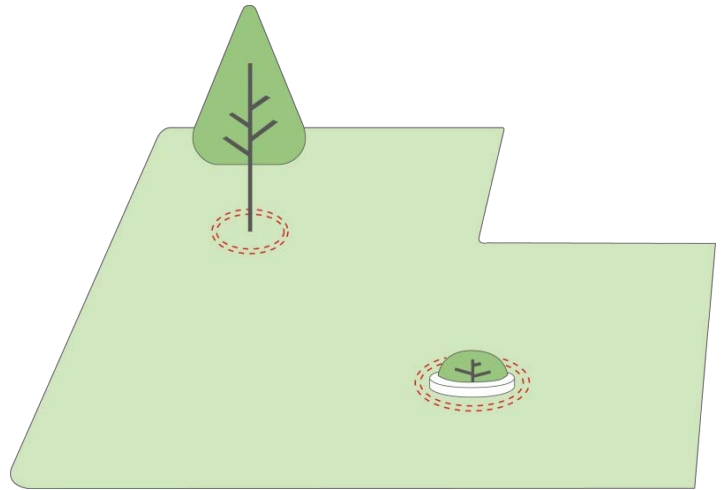

Path order

- **Grid first**

The robot starts from the inner grid.

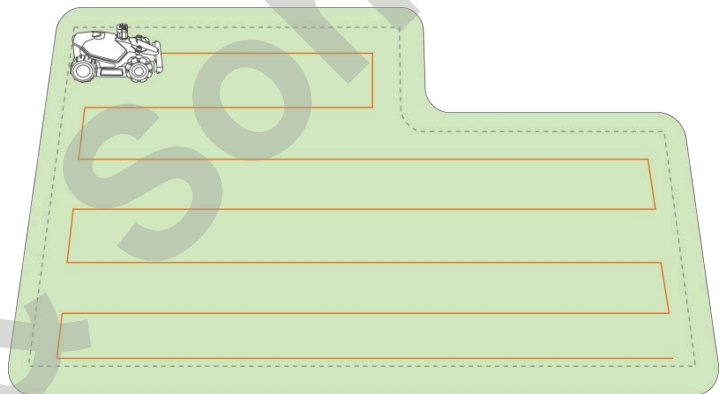

- **Perimeter first**

The robot starts mowing from the perimeter.

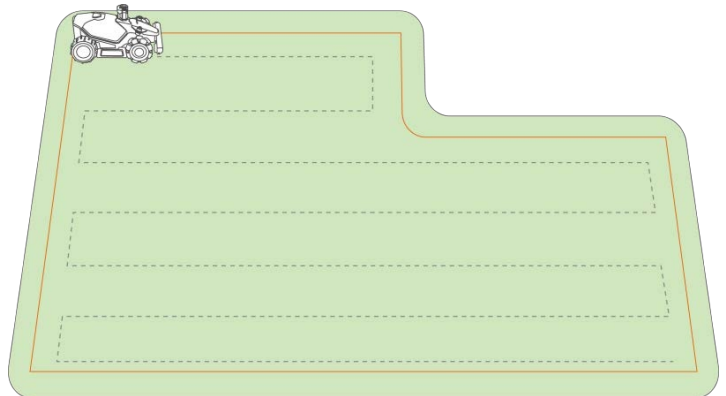



Start work from a specific percentage

The robot starts working from the set percentage.

4.8 Task schedule

Using the Schedule function, you can set up a recurring task and the robot will automatically carry out its work according to your settings.

4.8.1 Setting up a schedule

1. Tap **Add** on the home screen or tap **Tasks** on the Map page to go to the Task page.
2. Select the area you want to mow.
3. Tap  on  to configure the settings.
4. Tap  on the **Save** to apply the settings.
5. Tap the **Start** option to begin work, or tap **Save** to create a task schedule.





NOTE



- Adding a task schedule is temporarily disabled whilst the robot is working.
- Once the workspace has been created, you can set the schedule.
- For details on the settings, see the [Task Settings](#) section.

4.8.2 Editing a timetable

On the Map page, tap **Tasks** to access the list of schedules. Tap the '...' option on the selected schedule to open a drop-down menu.

- **Enable** – switch the '  ' button to 'Off'  to deactivate the schedule if necessary.
- **Rename** – tap to change the name of the schedule.
- **Edit** – tap to edit the schedule.

- **Run now** – tap to run this schedule immediately.
- **Copy** – tap to create a new schedule with the same settings whilst keeping the original schedule, then select the schedule you want to edit.
- **Delete** – tap to delete the schedule.

If an exclamation mark appears  , this means that the task schedule cannot be executed due to errors. Tap the exclamation mark to view further details.

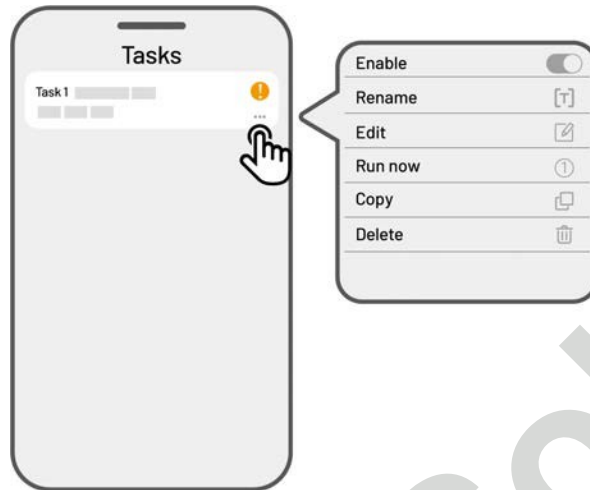

4.9 Manual mowing

If you prefer to mow your lawn manually, the Manual Mowing feature is available. To ensure your safety, use the **Manual Mowing** feature with care and observe the following:

- Minors are not permitted to use this feature;
- To prevent accidents, always supervise your children, pets and valuables;
- To prevent injury, take extreme care when using the manual mower function.
- When mowing manually, you are fully responsible for the operation of the mower.

4.9.1 Activating manual mowing

1. Tap the robot icon to go to the Map page.
2. On the Map page, select Manual.
3. Tap the **Manual/Hand mowing** option and drag the button to the right to start the mowing disc.
4. Move the robot forwards/backwards or turn it left/right to start mowing manually.



NOTE

- The cutting disc stops automatically after 5 seconds of inactivity.
- Swipe right as instructed by the app to start the mowing disc after each stop.

4.10 Activating FPV mode

FPV mode (first-person view mode) offers an immersive way to control and monitor the robot. When this mode is activated, the robot's on-board camera will stream live video, allowing you to see directly from the robot's perspective and control and navigate it more effectively.

Furthermore, FPV mode can transform your robot into a mobile security camera, providing real-time video surveillance and allowing you to remotely monitor various locations from the robot's perspective.

➤ **How to activate FPV mode**

- While the robot is working, tap **the FPV icon** on the work page.

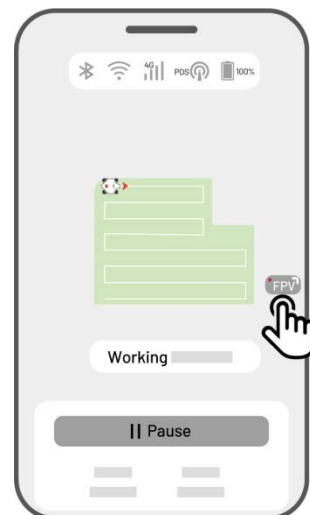

- On the Manual Mowing page, tap the **FPV** icon.

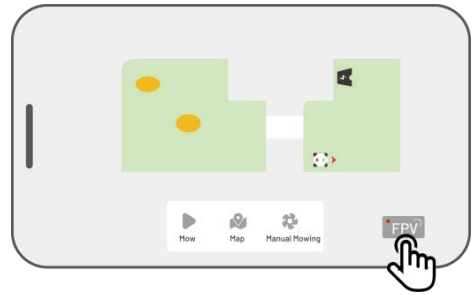







- On the Map page, tap the **FPV** icon.

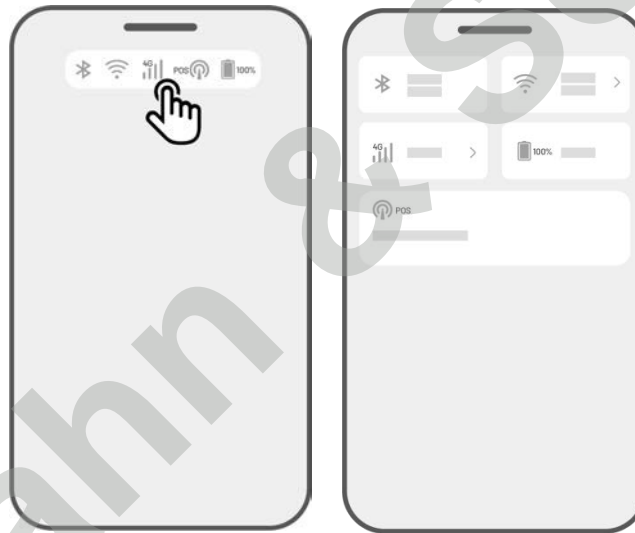

4.11 Viewing the status

Tap the **status bar** to view the device status.



Icon	Name	Description
	Bluetooth	Indicates a Bluetooth connection signal.
	Wi-Fi connection	Indicates the signal strength of the connected Wi-Fi network.
	4G connection	Indicates the strength of the mobile signal.
	Battery level	Indicates the remaining battery charge.
	Positioning status	Indicates the positioning status.

- The positioning status indicates the strength of the LiDAR module's position detection.
 - ◇ **Good** - good positioning status.
 - ◇ **None** - no positioning status.

4.12 Settings

Tap  to go to the Settings page.

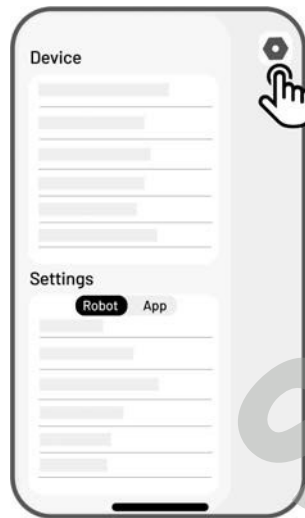

4.12.1 Device settings

- **Device information**
 - ◇ **Device Name** – change the robot's name.
 - ◇ **Share management** – tap to view your sharing history and share the device with your family.
 - ◇ **Robot version** – check the robot's firmware version.
 - ◇ **Firmware version history** – displays a log of updates and changes made to the device's firmware.
 - ◇ **Network settings** – the robot's network settings.
 - ◇ **Upload logs** – tap to send your issues and logs to Mammotion for troubleshooting.
You can attach up to 5 images and 1 video.
 - ◇ **Factory reset** – tap to perform a factory reset. All logs and Wi-Fi passwords will be deleted.
 - ◇ **Maintenance** – displays information on total mileage, mowing time, battery cycle and activation time.

- ◇ **Remove robot** - tap to disconnect the current robot. A robot can only be linked to one account and cannot be operated until it is connected to an account. If you wish to transfer ownership of the robot, you must remove the robot from the account before proceeding.
- **Network settings** – the robot's network settings.
- **Task log** – displays a history of completed and uncompleted tasks.
- **Upload logs** – tap to send your issues and logs to Mammotion for troubleshooting. You can attach up to 5 images and 1 video.

4.12.2 Robot settings

- ◇ **No mowing on rainy days** – if you enable this feature, the robot will not mow when it is raining.
- ◇ **Wildlife-safe mode** – designed to minimise the risk to wildlife at night.
- ◇ **Side LED** – tap to turn the robot's side indicator light on or off.
- ◇ **Automatic lighting** – when enabled, the robot's auxiliary light is automatically activated in low ambient light conditions.
- ◇ **Period without work** – tap to set the period without work.
- ◇ **Delete map** – tap to delete the current map.
- ◇ **Move charging station** – tap to move the charging station. For more information, see the section on ***Moving the charging station.***
- ◇ **Voice settings** – tap to switch between male and female voices.

Wildlife Safety Mode

Night-time safety speed

When this feature is enabled, the robot's maximum speed in automatic mode at night is limited to less than 0.3 m/s.

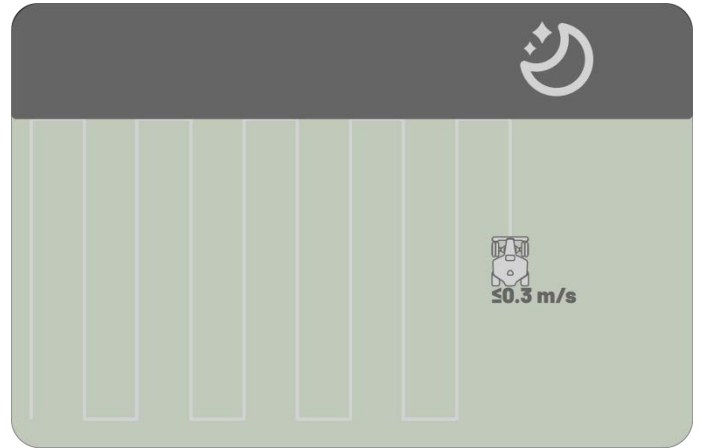

No tasks at night

If this function is enabled, the robot will not perform any tasks at night. Active tasks will also be paused and the robot will return to the charging station.

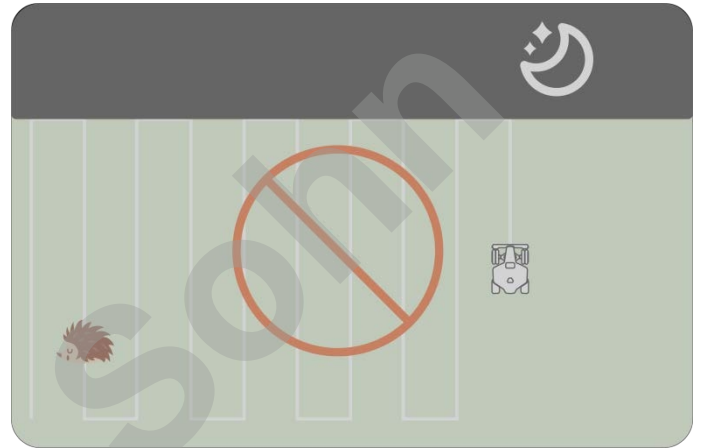

Move the charging station



NOTE

Use the Move Charging Station function whilst the robot is charging.

As a general rule, the charging station should be moved if:

- The charging station has been moved.
 - The charging station has been replaced.
 - The docking track has a significant slope.
 - The charging process consistently fails.
1. Install the charging station in the correct location.
 2. Place the robot on the charging station and make sure that the positioning status is correct.
 3. Select **Settings > Move Charging Station** under .

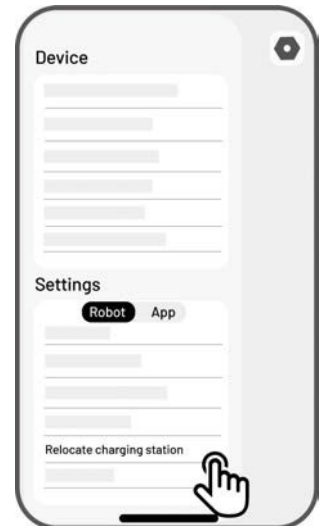



4.12.3 Charging – returning to the charging station



NOTE

When using the recharge - return to charging station function, the robot must be within the working area.

How to perform recharging

- Tap  on the map page in the Mammotion app, or
- Press the  button on the robot, then press the  button to guide the robot to the charging station.

4.13 Service page

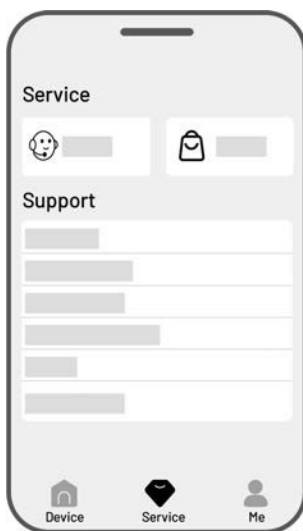

- **Help** – tap here to access our customer service.
- **Shop** – tap to go to the Mammotion shopping centre.
- **Academy** – tap to access user guides.
- **Tutorial videos** – tap to access tutorial videos.
- **User manual** – tap to open the user manual.
- **Winter maintenance** – tap to view details on winter maintenance.
- **Frequently Asked Questions** – displays common questions and answers.
- **About us** – tap to view further information about Mammotion.

4.14 Profile

- **Device management and sharing** – tap to share your devices.
- **Find my device** – tap to track your device.
- **Alexa** – tap to link your Alexa account.
- **Google Home** – tap to link your Google Home account.
- **Guide** – toggle on/off to show/hide the guide.
- **Language** – switch the language.
- **Upload logs** – send your issues and logs to Mammotion for troubleshooting.
- **About Mammotion** – tap to view the app version, user agreement and

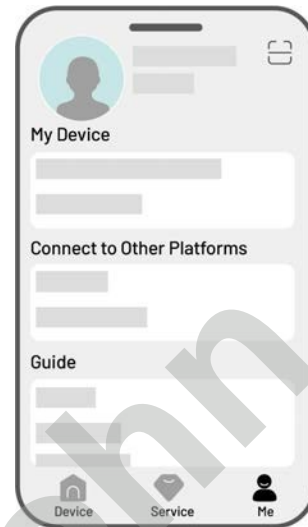

4.14.1 Share your device

Device sharing allows the recipient to control and access device information, but they cannot share it further or use the anti-theft feature.

1. Go to the 'Me' page and tap **'Manage and share devices'**.
2. Select the device you want to share.
3. Tap on the **Share with people** and continue.

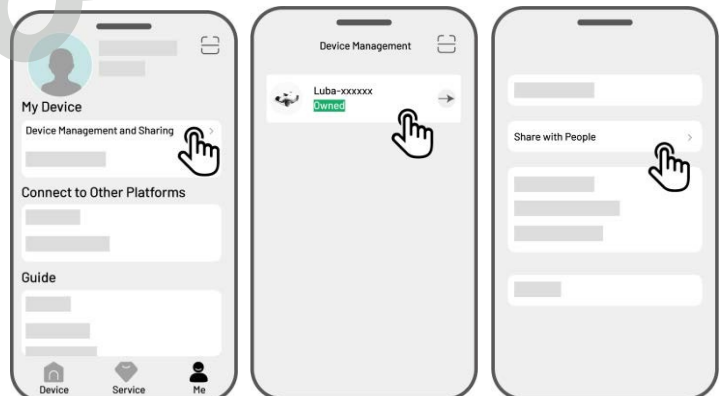

4. Select **Share via account** or **Share via QR code** and share your device.

● **Share via account**

a. Tap **Share via account**.

b. Enter the of the account you you

share, and tap **Share**.

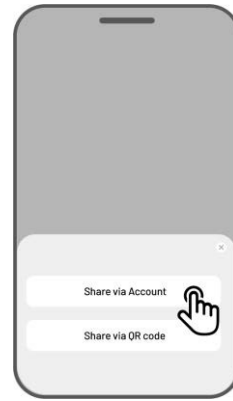

c. In the Mammotion recipient, tap

Agree.

● **Share via QR code**

a. Tap '**Share via QR code**' and the code will appear.

b. Use the Mammotion app to scan the QR code, and in the pop-up window, tap

Agree.

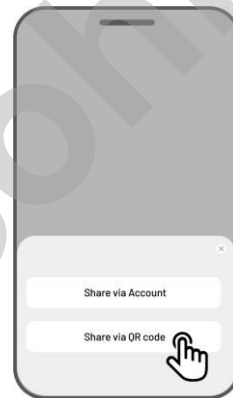

4.14.2 Stopping device sharing

For the owner

1. Go to the Me page and tap **Manage and share devices**.

2. Select the device you have shared.

3. Tap **Manage sharing** to continue.

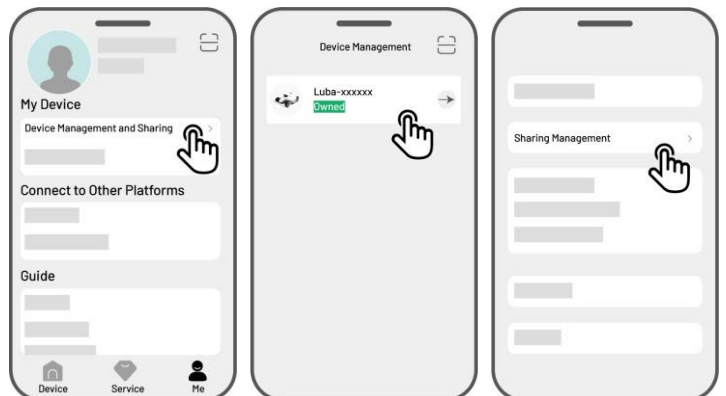

4. Select the relevant sharing history and tap

Remove.

5. Tap on the **Confirm** to revoke the recipient's access to the device.

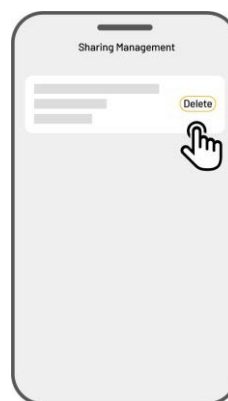

For the recipient

1. Go to the 'Me' page and tap **'Manage and share devices'**.

2. Select the device that has been shared with you.

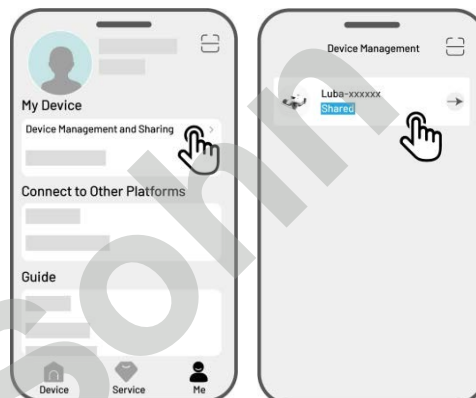

3. Tap **Remove.**

4. Tap on the **Confirm** device, you will stop using it. This action will not affect the owner's data.

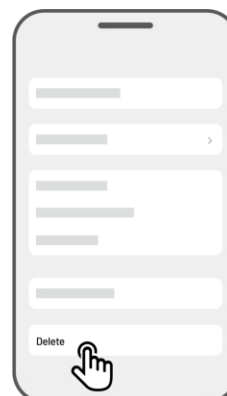

4.14.3 Find My Device

If your robot, which was connected to the Mammotion app, is missing, go to the **Me > Find My Device** page and track your device.



Tapping on the device will take you to the next page, where you can enable/disable **location notifications** and the **location log**.

- **Location notification** – if the robot is more than 50 metres from the work area, you will receive a push notification once the feature has been enabled.
- **Location Log** – once the feature is enabled, record the robot's location history.

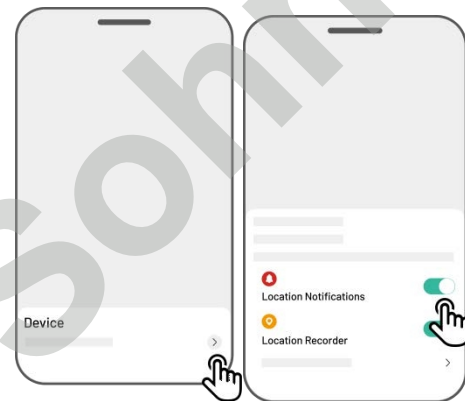

4.14.4 Linking your Alexa account

NOTE

- Before you start working with voice control, you must first create at least one task.
- In cases where more than two sets of robots are linked to the same Mammotion account, the voice command will, by default, be directed at the most recently linked robot.
- The robot now supports voice commands in English, German and French.

1. Go to the **Profile** page and tap **Alexa**.
2. Continue by selecting **LUBA 2 (Mammotion robot)**.
3. Tap the **Connect Alexa Assistant** option to go to the authorisation page.
4. Finally, complete the process by tapping **Connect**.

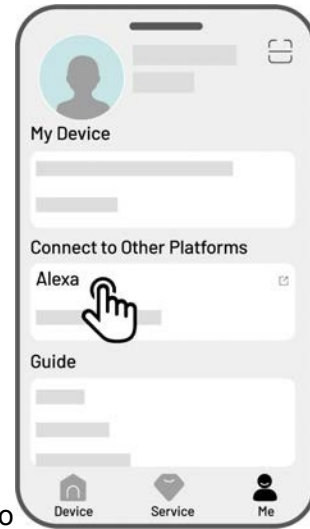

Once the connection is successful, you can control the robot using voice commands. Here are some examples for starting, pausing, stopping, recharging and checking the status:

Starting work

- Alexa, ask the Mammotion robot to start working
- Alexa, ask the Mammotion robot to start task xx (xx stands for the name of the task you have set) **Pausing**
- Alexa, ask the Mammotion robot to stop
- Alexa, ask the Mammotion robot to wait **Continue**

working

- Alexa, ask the Mammotion robot to continue **Stopping**

work

- Alexa, ask the Mammotion robot to stop working **Return to the**

charging station

- Alexa, ask the Mammotion robot to recharge
- Alexa, ask the Mammotion robot to go home **Check**

status

- Alexa, ask the Mammotion robot for its status

4.14.5 Linking your Google Home account



NOTE

- Before you start using voice control, you must first create at least one task.
- The robot now supports voice commands in English, German and French.

1. Go to the **Profile** page and tap **Google Home**.
2. Tap the **Connect Google Home** option to go to the permissions page.
3. Follow the instructions to complete the setup.

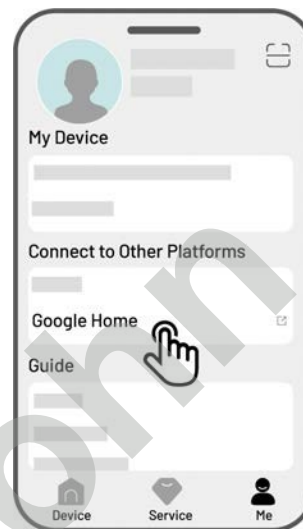

Once successfully connected, you can control the robot using voice commands; try the following commands: **Start**

working

- Hey Google, start mowing
- Hey Google, start the LUBA robot now
- Hey Google, let the LUBA robot run
- Hey Google, start the LUBA robot **Work**

paused

- Hey Google, pause mowing
- Hey Google, pause the LUBA robot now
- Hey Google, make the LUBA robot pause
- Hey Google, pause the LUBA robot

Resume work

- Hey Google, continue mowing
- Hey Google, let the LUBA robot continue
- Hey Google, let the LUBA robot continue

Stop working

- Hey Google, stop mowing
- Hi Google, stop the LUBA robot
- Hey Google, let the LUBA robot stop
- Hey Google, stop the LUBA robot

Charging the LUBA robot

- Hey Google, dock the LUBA robot
- Hey Google, let the LUBA robot go home
- Hey Google, tell the LUBA robot to go home

Status check

- Hey Google, is the LUBA robot running?

5 Maintenance

To maintain optimal mowing performance and extend the life of your robot, Mammotion recommends carrying out regular checks and maintenance every week. For safety and efficiency, always wear protective clothing such as trousers and work boots; do not wear open sandals or walk barefoot during maintenance.

5.1 Cleaning



WARNING

- Before starting any cleaning work, ensure that the robot is completely switched off and remove the key from the robot.
- Always switch off the robot before turning it over onto its wheels.
- When turning the robot over onto its wheels, handle it with care to avoid damaging the LiDAR module.

5.1.1 Cleaning the robot

Housing

Use a soft brush or a damp cloth to clean the robot's casing. Do not use alcohol, petrol, acetone or other corrosive or volatile solvents, as these may damage the robot's appearance and internal components.

Chassis

Wear protective gloves when cleaning the chassis and mower discs. Use a brush or plastic scraper to remove dirt. Check the blades for damage and ensure that the blades and mowing discs can rotate freely. DO NOT use sharp objects to clean the chassis. Never spray water onto the robot's chassis.

Front wheels (omnidirectional wheels)

Clean the front wheels with a brush or a damp cloth. Remove any mud. If the wheels are badly worn, replace them.

Rear wheels

If the rear wheels are too dirty, clean them regularly with a brush or a damp cloth.

LiDAR module

Wipe the LiDAR module and the AI-tracking camera with a microfibre cloth to remove any dirt or smudges. Keeping the optics clean is essential for optimal performance.

Rear section

Clean the rear charging contacts and the infrared receiver regularly with a cloth to remove grass clippings and dirt. Keeping these parts clean ensures proper charging and prevents charging faults. Prevent slugs from getting onto the contacts, as they can cause irreversible damage.

5.1.2 Cleaning the charging station

Use a soft brush and a dry cloth to clean the infrared transmitter and charging contacts.

5.2 Maintenance of the cutting blades and motor

WARNING



- Always wear protective gloves when inspecting, cleaning or replacing the cutting disc.
- DO NOT use an electric screwdriver to tighten or loosen the mower blade. Always use the correct screws and genuine blades approved by Mammotion.
- Replace all cutting blades and their bolts at the same time to ensure the cutting system remains safe and effective.
- DO NOT reuse bolts, as this could result in serious injury.

- To ensure optimum performance during long-term storage, keep the hub motor shaft dry and clean. Regular maintenance of the motor shaft helps prevent the build-up of dirt and moisture, which can impair motor function.
- Blades are considered wear parts and should be replaced if they become severely worn. We recommend replacing the cutting blades every 1-3 months or after a maximum of 100 hours of use. With denser grass, more frequent blade replacement may be necessary.
- Wet grass is more likely to stick to the blades and the underside of the mower, which can impair performance and lead to the need for more frequent cleaning. For optimal performance and the long-term health of your lawn, it is recommended to avoid mowing in heavy rain or when the grass is too wet.

How to replace the cutting blade

1. Switch off the robot and remove the key.
2. Place the robot on a soft, clean surface and make sure it is in the wheel-up position. Take care not to press on the LiDAR module.
3. Use a Phillips screwdriver to remove the old cutting blades.
4. Use the screws to fit the new cutting blades. Ensure that the blades can rotate freely and are securely fitted.

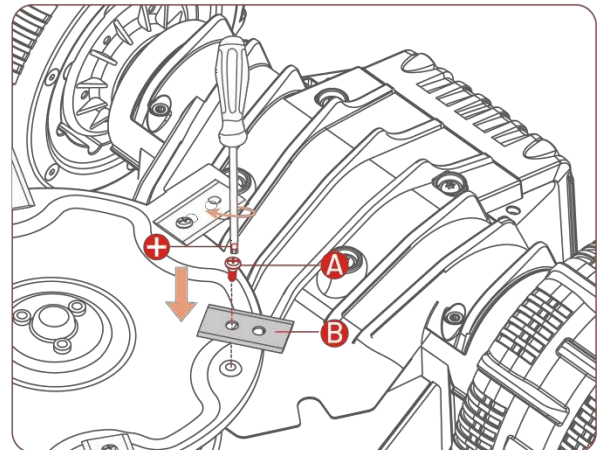
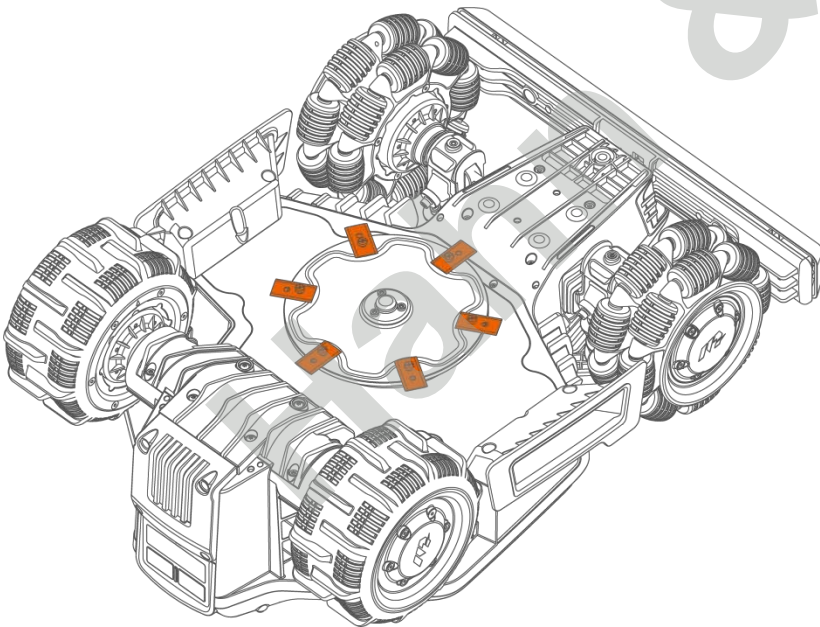

5.3 Battery maintenance

- Keep the battery fully charged before long-term storage to prevent over-discharge.
- Perform a full charge every 90 days, even if you are not using the robot.
- Before storing or charging, make sure the charging ports on the robot are clean and dry.

5.4 Winter storage

To ensure your robot is in optimal condition for the next mowing season, store the robot and charging station correctly. If the ambient temperature drops below $-20\text{ }^{\circ}\text{C}$ during winter, keep the robot and charging station indoors.

5.4.1 Storing the robot

- Move the robot away from the charging station and ensure that it is fully charged.
- Switch off the robot.
- Clean the robot (casing, wheels, chassis, LiDAR module, etc.) with a damp cloth or a soft brush. Never wash the robot with water.
- Allow the robot to dry. DO NOT turn it upside down during this process.
- Apply anti-corrosion lubricant to the charging contacts. DO NOT use chemicals on any other parts of the robot, especially on metal contact surfaces, with the exception of connectors.
- Store the robot indoors.

5.4.2 Storing the charging station

- Disconnect the power supply.
- Remove the rain cover if necessary.

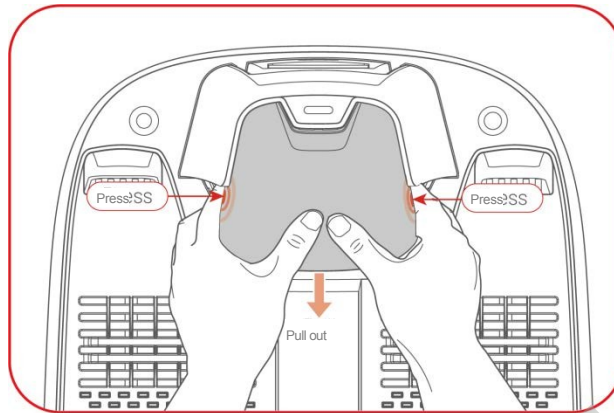

- Remove the pins.
- Use a soft brush and a cloth to clean the charging station thoroughly.
- Remove the charging station and the power supply.

Reinstall the charging station for the next mowing season, then relocate it (for more information, see the section 'Relocate the charging station') and use the Mammotion app to remap the route between the charging station and the working area.

6 Product specifications

6.1 Technical data

Table F6-1 General specifications

Technical specifications	LUBA mini AWD LiDAR
	1500
Recommended mowing area	1500 m ²
Max. mowing area	1600 m ²
Max. multi-zone management	20
Engine	All-wheel drive (AWD)
Max. climbing ability	80% (38.6°)
Ability to negotiate vertical obstacles	50 mm
Cutting width	200 mm
Cutting height	20–65 mm
Charging time	up to 200 minutes
Cutting time per charge	up to 150 minutes
LiDAR detection range	30 m
Automatic recharging	YES
GPS tracking in the event of theft	YES
Geo-alarm	YES
GeoFence tracking	YES
Lift Sensor	YES
Tilt sensor	YES
Charging station	CHG4310
Positioning and navigation	LiDAR and AI tracking

Technical specifications	LUBA mini AWD LiDAR
	1500
Obstacle avoidance	LiDAR and AI tracking and physical bumper
Voice control	Alexa and Google Home
Tracking monitoring	YES
Connectivity options	4G, Bluetooth and Wi-Fi
Weighted sound power	$L_{WA} = 64$ dB, $K_{WA} = 3$ dB
Weighted sound pressure	$L_{PA} = 56$ dB, $K_{PA} = 3$ dB
Water resistance	Robot: IPX6 Charging station: IPX6
Rain detection	YES
Net weight	16.5 kg
Dimensions (L × W × H)	584 × 430 × 307 mm

Table f6-2 Specifications of the LUBA mini AWD LiDAR (EU) on-board operating bands

Operating frequency		Maximum transmission power
LORA	863.1–869.85 MHz	<13.98 dBm
Bluetooth	2,400–2,483.5 MHz	< 20 dBm
Wi-Fi	2,400–2,483.5 MHz	< 20 dBm
	5,500–5,700 MHz	< 20 dBm
	5745–5825 MHz	<13.98 dBm
GSM900	880–915 MHz (Tx), 925–960 MHz (Rx)	35 dBm
GSM1800	1710–1785 MHz (Tx), 1805–1880 MHz	32 dBm
WCDMA Band I	1920–1980 MHz (Tx), 2110–2170 MHz (Rx)	25 dBm
WCDMA Band VIII	880–915 MHz (Tx), 925–960 MHz (Rx)	25 dBm
LTE Band 1	1920–1980 MHz (Tx), 2110–2170 MHz (Rx)	25 dBm
LTE Band 3	1710–1785 MHz (Tx), 1805–1880 MHz (Rx)	25 dBm
LTE Band 7	2500–2570 MHz (Tx), 2620–2690 MHz (Rx)	25 dBm
LTE Band 8	880–915 MHz (Tx), 925–960 MHz (Rx)	25 dBm
LTE Band 20	832–862 MHz (Tx), 791–821 MHz (Rx)	25 dBm

Operating frequency		Maximum transmit power
LTE Band 28	703–748 MHz (Tx), 758–803 MHz (Rx)	25 dBm
LTE Band 38	2570–2620 MHz (Tx), 2570–2620 MHz (Rx)	25 dBm
LTE Band 40	2300–2400 MHz (Tx), 2300–2400 MHz (Rx)	25 dBm
GNSS	1559–1610 MHz	NOT APPLICABLE

Table f6-3 Battery parameters

Parameters	Technical parameters
	1500
Battery charger	TS-A081-2703002 Input: 100–240 V AC, 50/60 Hz, 2 A Output: 27 V DC, 3 A, 81 W
Battery	21.6 V DC, 6.1 Ah
The charging temperature range is 4–45 °C.	
WARNING: For battery charging purposes, use only the detachable power supply unit supplied with this appliance.	

6.2 Error codes

The app notification displays common error codes along with their causes and troubleshooting steps. The most common issues are listed below.

Error codes	Causes	Solution
316	The left mower blade motor is overheating.	Once the motor has cooled down, the robot will return to normal. This process may take a few minutes.
318	The sensor for the left mower blade motor has failed.	Restart the robot. If the problem persists after several restarts, contact the after-sales team.
323	The right-hand mower disc motor is overloaded.	Check that the mower deck is not jammed, and clear it if necessary. Alternatively, raise the cutting height.
325	The right-hand mower disc motor will not start.	Check that the cutting disc is not jammed. If it isn't, restart the robot. If the problem persists even after several restarts, contact the after-sales team.
326	The right-hand cutting disc motor is overheating.	Restart the robot. If the problem persists even after several restarts, contact the after-sales team.
328	The sensor for the right mower disc motor has failed.	Restart the robot. If the problem persists after several restarts, contact the after-sales team.
1005	Low battery	The robot will continue working after the battery the battery to 80%.
1300	The positioning status is poor.	Please wait for the robot to move.

Error codes	Causes	Solution
1301	The charging station has been moved.	Move the charging station.
1420	A time-out occurred whilst loading speed data , a timeout occurred.	Restart the robot. If the problem persists, contact the after-sales team.
2713	Charging has been stopped due to low battery voltage.	Restart the robot. If the problem persists even after several restarts, contact us the the after-sales team.
2726	The battery is overcharged.	Stop charging immediately. If overcharging occurs frequently, contact the after-sales team.
2727	The battery is too low.	Please charge the robot.

7 Simplified EU Declaration of Conformity

Shenzhen Mammotion Innovation Co., Limited hereby declares that the radio equipment type [Model: 1500] complies with Directive 2014/53/EU.

Full text of the of conformity EU is available at the following website address: <https://mammotion.com/pages/eu-declaration-of-conformity>.

Hahn & Sohn

8 Warranty certificate

Model:
Serial No.:
Date of sale:
Dealer's stamp:

This warranty certificate applies to products imported into the Czech Republic by BLAKAR trading s.r.o., business premises: Azalková 1272, 252 42 Jesenice, Company ID: 282343391, VAT No.: CZ28234391.

WARRANTY TERMS

- The product is covered by a 36-month quality guarantee from the date of sale to the consumer.
- The warranty covers defects demonstrably caused by faulty materials.
- The warranty does not cover defects caused by transport, failure to follow the operating instructions provided in the manual, poor maintenance, mechanical **damage**, tampering with the product, or faults caused by power supply failures, incorrect installation, or unsuitable placement (dusty, chemical or otherwise unsuitable environments).
- The warranty does not cover defects caused by normal wear and tear (in the case of batteries, this includes, in particular, loss of capacity; the battery's service life is at least 6 months from the date of sale, or wear and tear mower blades, mower discs, wheel tyres, etc.).
- To claim under the warranty, you must present proof of purchase (e.g. an invoice, receipt or a completed warranty certificate stamped by the seller)

Authorised service centre for the Czech Republic: BLAKAR trading s.r.o., Azalková 1272, 252 42 Horní Jirčany, Czech Republic

Tel.: +420 606 839 644, +420 774 737 789

(Mon-Fri 8.00 am-4.30 pm)

Email: servis@blakar.cz

www.lubasekacky.cz



Copyright © 2025, MAMMOTION All Rights Reserved.